

Instruction for use

Hartenberger

Underwater Hand Lamp

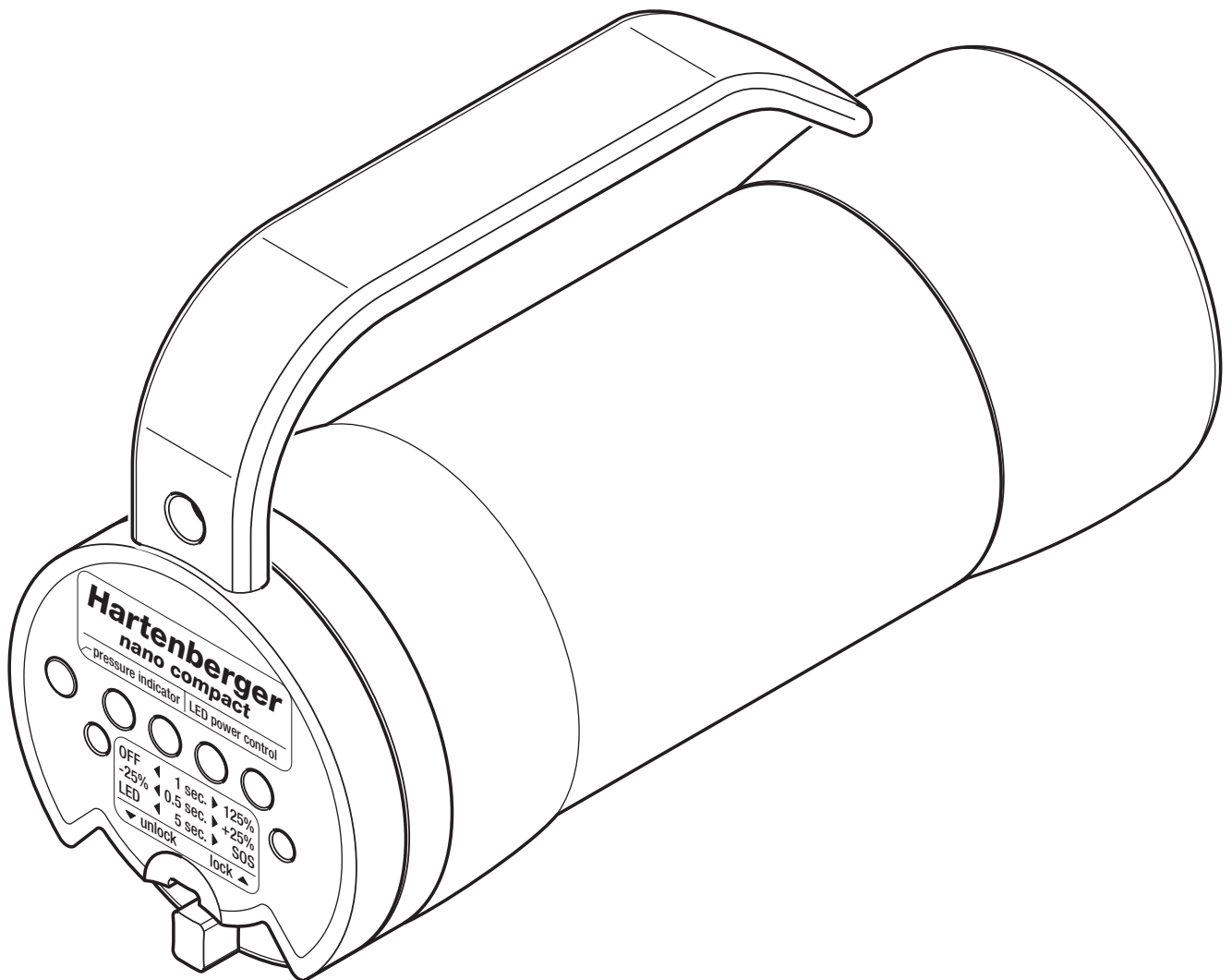

nano compact

CONTENTS

WARNING SIGNS	2
SAFETY WARNING	3
GUARANTEE	3
APPLICATIONS.....	3
ARTICLE DESCRIPTION HOUSING	4
ARTICLE DESCRIPTION POWER PACK	6
TECHNICAL SPECIFICATIONS.....	6
FRONT HOUSING COVER.....	7
BULB/LED	8
THE REAR HOUSING COVER	9
POWER PACK	11
PREPARATION FOR USE	11
USING THE UNDERWATER LAMP	12
TRANSPORT	15
STORAGE	16
CHARGING	16
CHARGER OFF-SHORE I/6.....	19
CHARGER OFF-SHORE II.....	20
CARE AND MAINTENANCE	21
FAULT DIAGNOSIS	22
SPARE PARTS.....	23
ACCESSORIES.....	23

WARNING SIGNS

If not adhered to the parts of this instruction for use, which are marked with the above warning sign, there is a danger of property damages or physical damages.



Warning !

If not adhered to the parts of this instruction for use, which are marked with the addition “Warning”, there is a great danger of property damages, physical damages or death.

**SAFETY WARNING**

Before attempting to use the underwater lamp, carefully read and adhere to these instructions for use.

The use of the underwater lamp nano compact calls for the same amount of care and conscientiousness as is necessary in order to practice diving in a safe manner. If the instructions are not followed, there is a great danger of personal injury as well as injury to property (danger of explosion).

GUARANTEE

When these instructions for use and the care and maintenance guidelines are adhered to, we will guarantee all mechanical parts made from steel, aluminium, glass and plastic for a period of 5 years against manufacturer's defects and material failure. All electronic parts are guaranteed for a period of 2 years. The rechargeable cells have a guarantee against manufacturer's defects and material failure for 6 months. Halogen bulbs and O-ring seals are expendable items and are therefore not covered by the guarantee. Any unauthorised work on the lamp, i.e. the removal or tightening of screws, or the removal of the guarantee seals, will make the guarantee invalid.

Warning !

The manufacturer's warranty expires if these instructions for use are not followed and strictly adhered to. If the lamp is tampered with or dismantled in part or full by an unauthorised workshop or technician, the warranty automatically expires, such tampering includes but is not limited to; loosening and/or tightening screws, the removal/damage of original seals. When purchasing the lamp make sure that the original manufacturer's seals are intact (1x housing electronics, 1 x cell electronics, charger off-shore II).

Warning !

If the lamp is tampered with and/or if unauthorised (from the manufacturer) parts/components (e.g. cells, electronics components, non-original chargers,) are used or installed in the lamp, this results in a change of original design and the warranty is automatically invalid. The manufacturer is also released from any product liability.

APPLICATIONS**Warning !**

The *nano compact* underwater lamps are for use in underwater lighting applications. Using the lamp in an environment other than water can lead to an overheating and consequently to a danger of explosion. In special cases please ask the manufacturer for release.

ARTICLE DESCRIPTION HOUSING

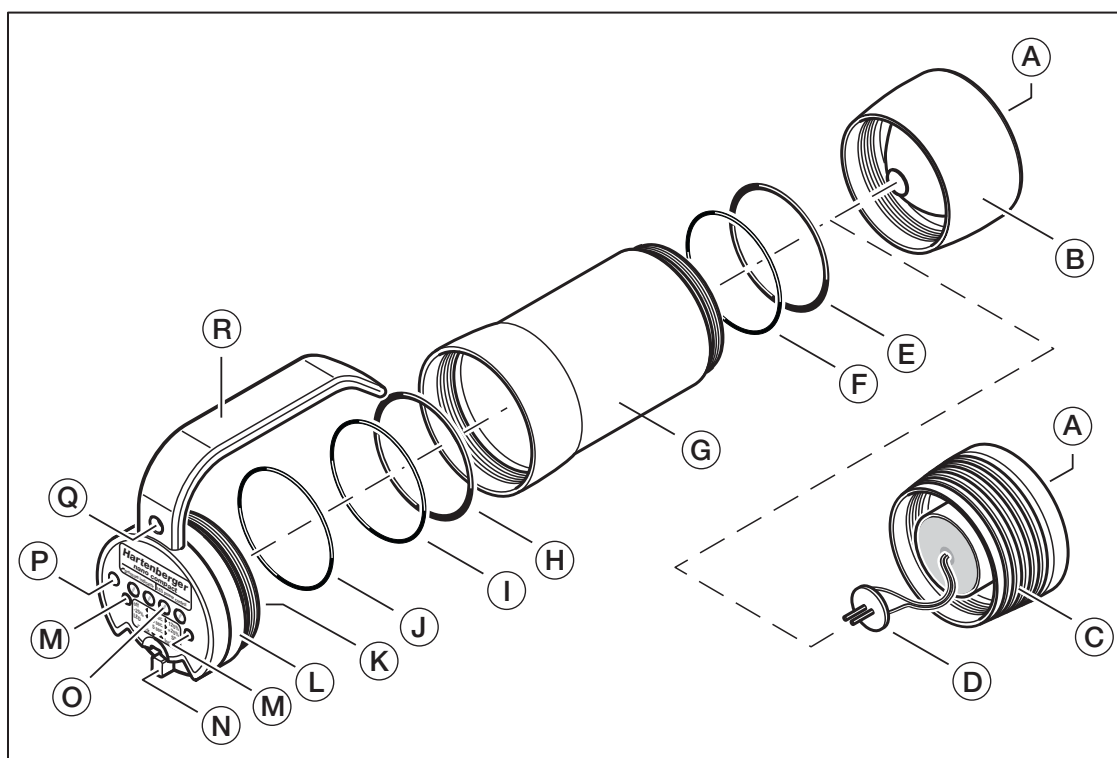

Fig. 1: housing

- Ⓐ FRONT SEAL / FRONT GLASS PLATE
The front glass plate with the O-ring (48 x 3 60° hardness) is pressed into the housing during the assembly by the manufacturer. It can only be opened by an authorised workshop.
- Ⓑ FRONT COVER (REFLECTOR COVER)
The standard front cover is equipped with a spot reflector for use with halogen bulbs. Flood reflectors and/or chemically matt coated front glasses are available as options.
- Ⓒ FRONT HOUSING COVER (LED-CONNECTION)
The front housing cover is also available with 4 x 3 Watt LED spots as an option.
- Ⓓ PLUG MODULE FOR LED OPERATION
The LED plug module is plugged in to the halogen bulb socket when the lamp is to be used with LEDs.
- Ⓔ Ⓕ O-RINGS
40 x 3,0 and 48x1,6 mm 50° hardness
- Ⓖ HOUSING / BODY
The housing / body is sealed with the front and the rear screw fitting.
- Ⓗ Ⓘ O-RINGS
40 x 3,0 and 48x1,6 mm 50° hardness.

- Ⓝ SPARE-O-RING
The spare O-ring (48 x 1,6 50° hardness) is located in the rear cover adjacent to the plastic cover.
- Ⓞ PLUG-IN CONNECTION
The plug in connection serves as an electrical and mechanical connection between the power pack and the electronic control panel.
- Ⓟ REAR HOUSING COVER
The rear housing cover can be removed for accessing/removing/replacing the cells pack and/or the halogen bulb.
- Ⓠ CHARGING CONTACTS
The charging contacts are for charging the cell pack while the housing is closed. The contacts are colour coded: +/red (right contact) and -/blue (left contact).
- Ⓡ MAGNETIC SWITCH / TRANSPORT LOCK
The magnetic switch is used for all the control functions of the lamp and the electronics. To lock the lamp and prevent inadvertent operation, the magnetic switch, press the switch „in“. This is the so-called transport setting.
- Ⓢ LED DISPLAY
The 4 LEDs show the brightness set and the remaining capacity of the cell pack.
- Ⓣ OVERPRESSURE INDICATOR
If the pin protrudes from the housing, and over pressure exists in the housing.
- Ⓤ HOLE FOR A LANYARD
The hole in the handle provides an attachment point for a lanyard for better security during use and may prevent loss of the lamp.
- Ⓥ HANDLE
The handle provides a good hold on the lamp, even when wearing thick neoprene gloves or mittens. If required for video mounting, the handle can be drilled and an M8 thread cut for mounting to video rigs.

ARTICLE DESCRIPTION POWER PACK

Fig. 2: power pack

- Ⓢ **HALOGEN BULB**
The 6V Halogen bulb is plugged into the G4 socket. The bulb can be removed for replacement or as a precaution during transport by simply pulling it out of the socket.
- Ⓣ **SPARE-O-RING**
The O-ring (40 x 3,0 50° Hardness) is located in a groove in the power pack.
- Ⓤ **HALOGEN BULB STOWAGE**
The halogen bulb stowage compartments can be used for storing spare bulbs and/or stowing the bulb during transport.
- Ⓥ **CELL PACK**
The cell pack is plugged in to the power pack and can be removed/replaced in seconds. The cell pack consists of a Lithium Manganese (LiMn) cell block, a micro processor electronic and the socket for the halogen bulb including stowage for 2 halogen bulbs.
- Ⓦ **CONTACT PINS**
The contact pins serve as an electrical and mechanical connection between the power pack and the housing electronic module and for charging the cell pack.

TECHNICAL SPECIFICATIONS

APPROX. BURN TIME IN MINUTES WITH LIMN CELL PACK 7,2V / 3,8AH

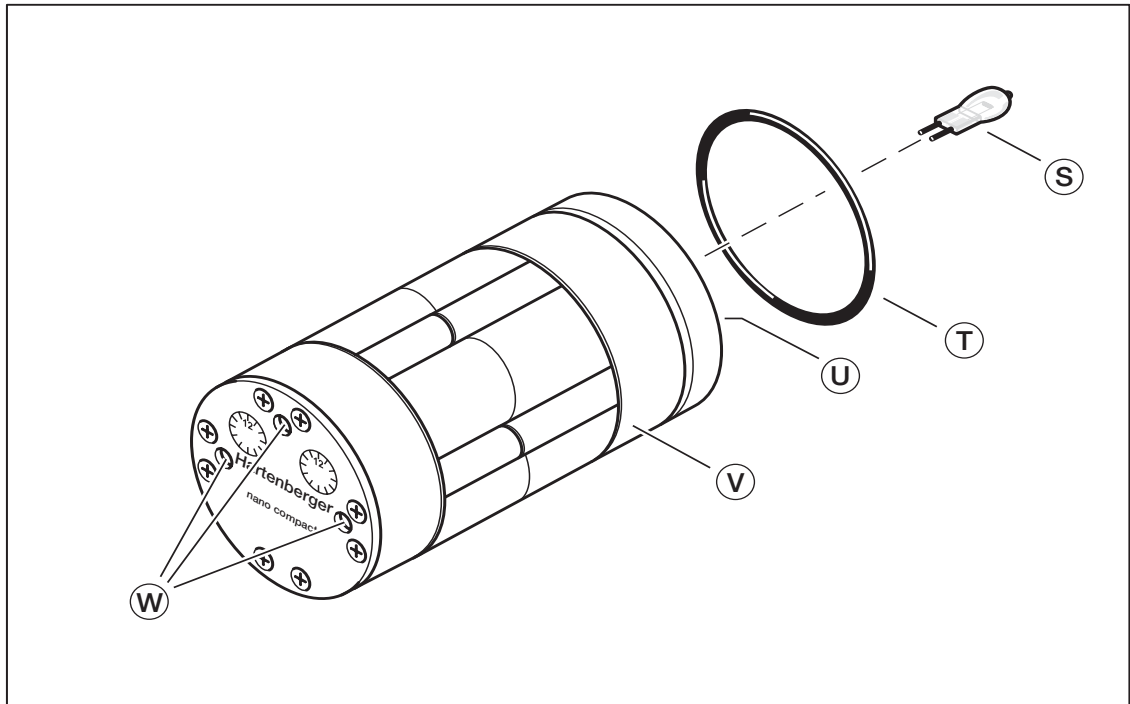
Halogen Bulb 6V	10W	20W	35W *	LED 4x3W
Time of use at 50%	260	130	70	150
Time of use at 75%	200	100	55	120
Time of use at 100%	130	65	35	75
Time of use at 125%	100	50	28	60

* only suitable for use in conjunction with the optional flood reflector.

The bold printed figures represent the burn times with the standard bulbs as supplied with the lamp from the manufacturer.

Halogen bulbs available in retail outlets often need up to 10% more power as stated. The stated burn times will therefore be shortened.

Low ambient temperature have little effect on lithium manganese cells. These special cells have approx 95% capacity in water temperatures between 0° and 5° Celsius (32° - 41° Fahrenheit).

A 3% - 10% reduction in performance over 12 Months can be regarded as normal life reduction.

DIMENSIONS/WEIGHT/PRESSURE RATING

Length & Diameter	weight on land	weight in water	Resistance to water Pressure
150mm x 59mm 6" x 2½"	0.6kg 1lb 5oz	0.2kg 7oz	100m 330 ft

FRONT GLASS PLATE

The nano compact lamps have a tempered glass plate as standard. This glass plate has a temperature shock resistance of 150°C (300°F). It is therefore possible to use the lamps above and under water. A rapid cooling of a heated front glass is no problem (for example if used temporarily above water in order to orientate oneself on the surface of the water).

FRONT HOUSING COVER

FRONT GLASS COVER

The O-ring (40 x 3,0 60° hardness) seals the front glass plate in the cover and is specially pressed into the cover by the manufacturer. This O-ring must be replaced every 5 years, or earlier if it shows sign of deterioration (such as cracking). This job may only be carried out by an authorised workshop

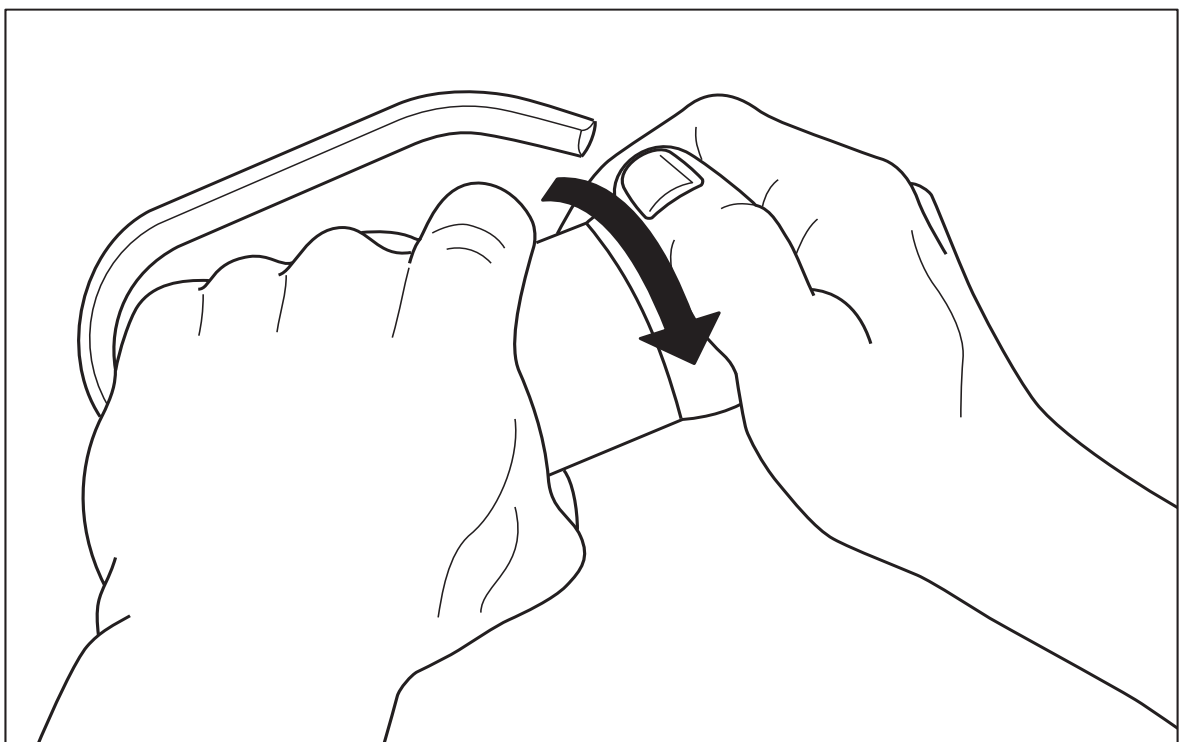

Fig. 3: Opening the front screw fitting

REMOVING THE FRONT HOUSING COVER

The front housing cover can be removed by unscrewing the cover anti-clockwise from the housing (thread length approx 10mm) see Fig. 3. To avoid damage to the halogen bulb, pull the front cover straight away from the housing.

CLOSING THE HOUSING

Before closing the housing, all threads, sealing surfaces and seals must be checked for integrity and cleanliness. Should the sealing surfaces and/or components be contaminated, then the O-rings (40 x 3,0 50° hardness and 48 x 1,6 50° hardness) and its groove should be thoroughly cleaned. Should the sealing surfaces and/or components be damaged, then all damaged parts should be replaced. If the O-ring is removed, care must be taken not to damage the groove in which the O-ring sits. A soft blunt tool should be used for the removal of the O-ring, i.e. a wooden tooth pick. Before the components are refitted it is recommended that a thin coating of silicone grease is applied as lubrication. It is recommended that after such work has been carried out, that the seal/integrity of the housing is first checked underwater without the power pack fitted. The housing is then closed by screwing the components clockwise together. The screw fitting should be tightened by hand only until the parts are mated together.

MAINTENANCE OF THE REFLECTOR

If the reflector mirror becomes dirty or is contaminated, it must be cleaned with a soft, dry cloth. Remove the front housing cover and then the reflector can be removed. First remove the O-ring (\varnothing 3mm, 50° hardness) using a blunt tool such as a tooth pick or similar, care must be taken not to damage the O-ring. Once the reflector has been cleaned, the O-ring can be refitted into the groove between the reflector and the housing cover, make sure the O-ring sits correctly into the groove, a blunt tool can be used for pressing the O-ring into the groove.

BULB/LED

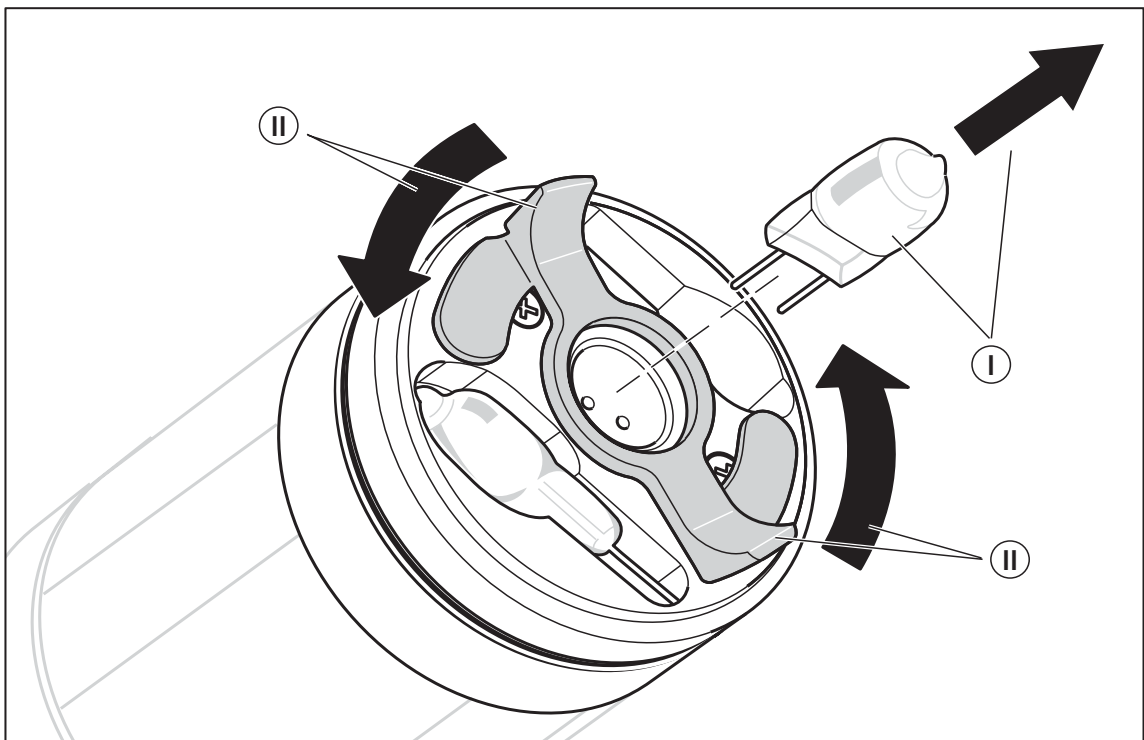



Fig. 4: Removal/Refitting the bulb

REMOVING / REPLACING THE HALOGEN BULB

The halogen bulb is accessible after opening the front and rear housing covers. Access to the halogen bulb stowage is easier when the rear housing cover is opened (see page 8).

RISK OF INJURY THROUGH BURNING!



The halogen bulb remains very hot for an extended period of time after use! Do not touch the halogen bulb with your bare fingers. Residue on your fingers can remain on the glass during normal use may form carbon. This will reduce the efficiency of the bulb. Use a clean cloth or tissue to remove the bulb from the socket. When refitting or replacing the bulb, ensure that it is located all the way into the socket. To produce an even illumination, it is imperative to ensure that the bulb sits upright in the socket. Assemble the lamp and check for correct fit and operation.



To prevent plastic components and the cells of the lamp from overheating and becoming damaged by heat, the halogen bulb should only be switched on when the housing is completely assembled and all covers are screwed tight.

SPARE HALOGEN BULB

There are 2 halogen bulb stowage compartments adjacent to the bulb socket. Bulbs are safely stowed in these compartments and the plastic cover prevents them from inadvertently falling out. This cover must be turned open to access the bulb stowage (see Fig.4, II).

LED MODULE

The optional LED-Module replaces the standard halogen bulb and front cover/reflector. The module is connected electrically by plugging it into the halogen bulb socket. (see fig. 1, ©). The plug arrangement prevents incorrect fitting/connection. If the lamp does not function properly, remove the plug module, rotate it 180° and refit it into the halogen bulb socket. Take care not to short circuit the contacts. To prevent the cable from over-twisting, turn the LED module 2-3 turns in the backwards before starting to thread the module into position. Do not use excessive force to tighten down the module, if resistance is felt, make sure the cable is not trapped and avoid damaging the cable.

REAR HOUSING COVER (THREADED CAP)

THE REAR HOUSING COVER SEALS

The double O-ring seals on the charging socket, the over pressure indicator and the lamp conductor insert can only be replaced by the manufacturer. Based on the experience gained to date, this service work should be carried out every 5 years. Our experience with other models indicates that these seals are in good condition after this period.

Please get the latest information from our web site

(http://www.hartenberger.de/pdf/e_bet_nano.pdf) on service intervals and recommended life spans the can change with time/experience.



The plastic components on the rear housing cover should not be exposed to any solvent based agents, such exposure may result in cracks in the components and subsequent leakage/flooding.

OPENING THE REAR SCREW FITTING

The housing is opened by unscrewing the fitting anti-clockwise, (thread length approx. 10 mm [3/8"]). Whilst opening the housing, it should be held in an upright position, thus preventing the power pack from inadvertently falling out.

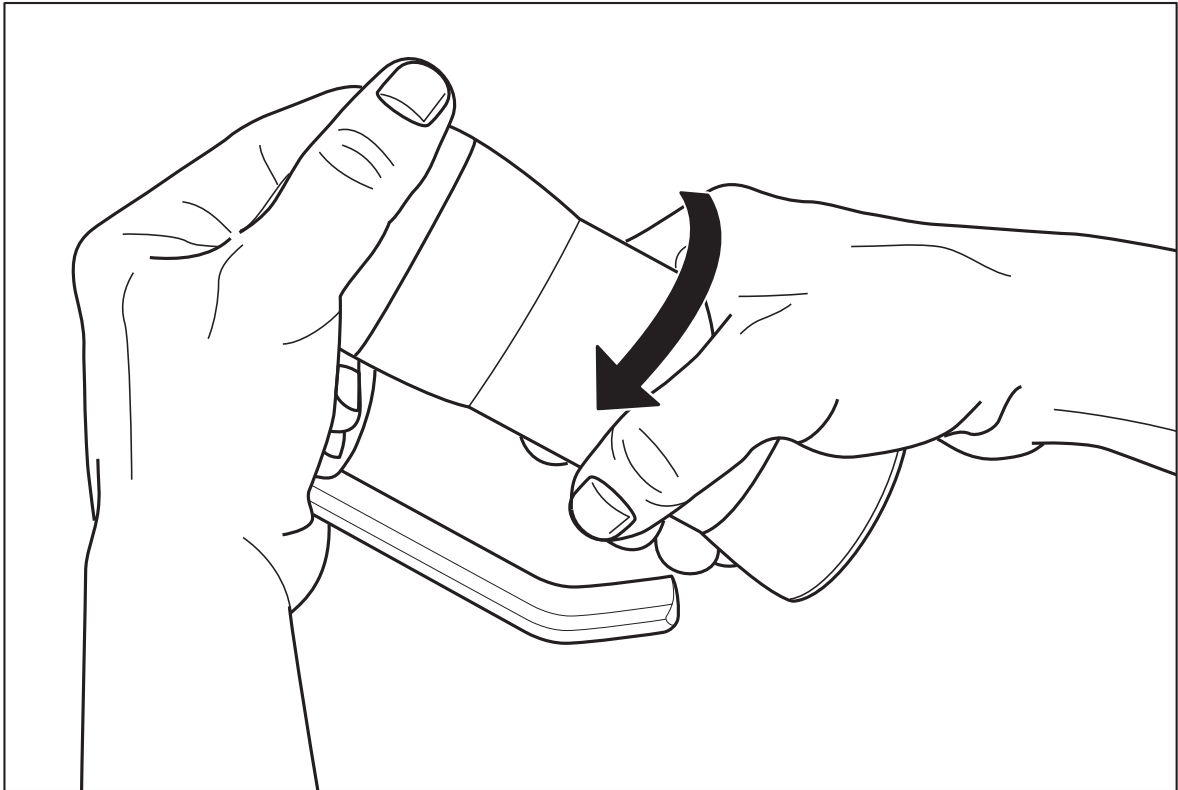

Fig. 5: Opening the rear screw fitting

CLOSING THE REAR SCREW FITTING

Before closing the rear screw fitting, all threads, sealing surfaces and seals must be checked for integrity and cleanliness. Should the sealing surfaces and/or components be contaminated, then the O-rings and its groove should be thoroughly cleaned. Should the sealing surfaces and/or components be damaged, then all damaged parts should be replaced. If the O-ring (40 x 3,0 50° hardness and 48 x 1,6 50° hardness) is removed, care must be taken not to damage the groove in which the O-ring sits. A soft blunt tool should be used for the removal of the O-ring, i.e. a wooden tooth pick. Before the components are refitted it is recommended that a thin coating of silicone grease is applied as lubrication. It is recommended that after such work has been carried out, that the seal/integrity of the housing is first checked underwater without the power pack fitted. The housing is then closed by screwing the components clockwise together. The screw fitting should be tightened by hand only until the parts are mated together.

POWER PACK

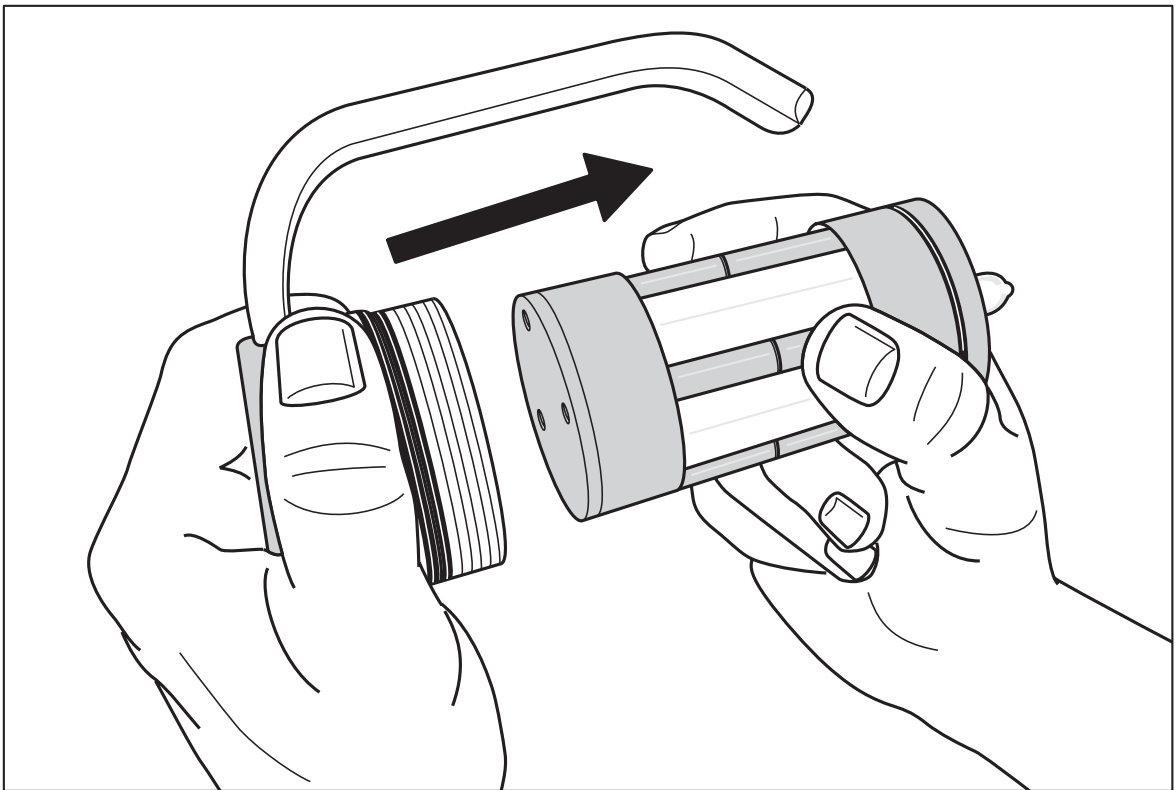

Fig. 6: Removal of the power pack

REMOVING THE CELL PACK

After removing the rear housing cover (see page 10), the complete cell pack can be unplugged and removed (Fig. 6).

The 3 pins serve as the mechanical and electrical connection between the cell pack electronics and the housing electronics.

There is stowage for a spare housing O Ring (48 x 1,6 50° hardness) located in the rear housing cover (adjacent to the plastic cover).

FITTING THE CELL PACK

Hold the rear housing cover upwards and carefully plug the cell pack onto the rear housing cover. Ensure that the 3 plugs on the rear housing cover are guided into the sockets carefully. The plug arrangement prevents incorrect connection. Push the cell pack fully down on to the pins without damaging/distorting the pins and without use of excessive force.

PREPARATION FOR USE

BEFORE THE LAMP IS USED FOR THE FIRST TIME

Before the first use, the cells must be charged. Hartenberger underwater lamps are manufactured to a high degree of precision and each lamp is tested to a water pressure of 10 bars. The condition of the lamp and in particular the housing and sealing rings should however be checked before the first use (see page 8).



Warning !

Due to damage during transportation or hidden material defects, leakage can occur (not the fault of the manufacturer). To check if the housing is pressure tight, the first dive should be carried out without the housing insert, i.e. empty.

BEFORE EACH USE

Before each use, the threads, sealing surfaces and O-ring must be checked for integrity and cleanliness. (See Closing the housing, page 8). If the bulb has been removed for transport, it should be refitted into the socket. Refit the halogen bulb in the socket which may have been removed for transportation. Only release the **transport lock** to the unlocked position immediately before use. (See page 12).

USING THE UNDERWATER LAMP**Warning !**

When the lamp is turned on, direct the beam away from yourself and others. Do not point the beam directly at others. If there is a defect on the lamp, the front glass plate may be forced out of the front of the housing with explosive force.

Warning !

Water inside the housing (especially sea water) can have drastic results consequences after some a period if time. Therefore, during the use of the lamp please check repeatedly, whether water has found its way inside. Do this by holding the lamp on the slant pointing down, thus the ray of light pointing away from the body. Then look at the front glass from the side. If there is water inside the housing, bring the dive to an end by following the diving rules and open the housing as soon as possible (see page 22).

TRANSPORT LOCK

Release the transport lock immediately before use.

To unlock the switch, push it from the transport lock position (lock) outwards (unlock) the switch must physically click into the unlocked position.

MAGNETIC SWITCH / SWITCH UNIT

The electronic controls are activated by pushing the switch to the right (+) or to the left (-). The signals are transmitted via magnetically sensitive hall sensors. This feature avoids any mechanical connection through the lamp's housing reducing the risk of water ingress and general wear.

ACTIVATING THE ELECTRONICS / CELL PACK CAPACITY DISPLAY

If the switch is pushed to the left (-) for approx. 3 seconds, the electronics are activated from the energy saving „sleep” mode. The LED display illuminates and shows the charge status of the cell pack for approx 3 seconds.

One LED = 25%, two LED's = 50%, three LED's = 75%, four LED's = 100%
To view the capacity display after the 3 seconds, Slide the switch one short push to the left (-) again.

If the lamp is not used for a period of 10 hours, the electronics will automatically return to the energy saving “sleep” mode.

BRIGHTNESS / DIMMER

The electronics allow the lamp to be used in 4 levels of brightness (50%, 75%, 100% and using over voltage; 125%).

Using the lamp at dimmed (lower) settings will save energy and extend the burn time of the lamp with one charge.

If the switch is pushed for a short time (approx ½ second) to the right (+), the lamp will turn on to the first brightness stage (50%).

Each subsequent push to the right (+) will increase the brightness 25%.

Each subsequent push to the left (-) will decrease the brightness 25%.

If the switch is pushed to the right (+) for longer (approx. 1 second), the lamp will turn on to the highest brightness stage (125%).

If the switch is pushed for approx 1 second to the left, the lamp will switch off immediately.

If the switched is pressed down for approx. 3 seconds, the LEDs will show the brightness currently set.

One LED = 50%, two LED's = 75%, three LED's = 100%, four LED's = 125%

After another 3 seconds, the display then indicates the current cell pack capacity.

When the lamp is turned off, the LED display will also switch off. Sliding the switch to the left will then activate the LED display and shows the current cell pack capacity, this remains visible for approx 3 seconds.

SOS WARNING / DISTRESS SIGNAL

The electronics have the facility to transmit an SOS signal in Morse alphabet (2 x short, 3 x long, 3 x short).

If the switched is pressed for an extended time (approx. 5 seconds) to the right (+), this function is activated and the lamp begins to blink SOS.

Pressing the switch to the left (-) for approx. 1 seconds stops the SOS signal. The time that the lamp will generate the SOS signal is approx. 3 times longer than the continuous burning time of the halogen bulb fitted. When the cell pack is almost fully discharged, the SOS signal will fade and dim. **Only use the SOS function in a distress or emergency situation. If the lamp fades, turn the signal off and only turn it back on when help is in sight.**

EMERGENCY LIGHTING (AUTOMATIC)

The lamp's electronics will automatically sense a defective bulb and will automatically turn on all the LEDs. This serves as an emergency source of light for reading instrumentation or for orientation in a very dark environment. To turn the emergency lighting off, push the switch to the left (-). Pushing the switch to the right (+) will reactivate the emergency light.

EMERGENCY LIGHTING (MANUAL)

The emergency light (all 4 LEDs are illuminated continuously) may be activated manually. Push the switch to the left for approx. 5 seconds. This emergency light will last longer than the normal bulb burning time and will provide you with an emergency source of light for reading instrumentation or for orientation in a very dark environment. To turn the emergency lighting off, push the switch to the left (-). The emergency light function will not activate after the lamp has turned off automatically in the discharge protection mode.

OVER-VOLTAGE / DIMMER

The HLX bulbs which we use have a much greater efficiency than standard halogen bulbs. Using a 6 cell power pack, we have a power supply of 7,2 volts. This allows the 6v bulb to be operated continuously with an over-voltage of approx. 6,8 volts. The electronics switch the bulb on slowly thus preventing the coil in the bulb from burning out. The resulting increase in brightness is approx. 30% more than the stated power. The micro controller can accurately monitor the energy dissipation to the bulb and ensures a continuous colour temperature over the entire discharge process and operation. The life expectancy of the bulb of approx. 100 hours is not reduced. Using the lamp at reduced power settings saves energy and extends the burning time in a single charge cycle. Permanently operating the lamp at reduced power settings will however produce a grey coating on the bulb's

glass. If reduced brightness is required on an extended basis, then a lower power rating halogen bulb is recommended.

LOW LEVEL CAPACITY WARNING

When the lamp blinks 3 times, the user is warned of the immanent end of the burn time of the lamp. When the lamp is being used with the standard 20 watt halogen bulb at 100% power, this will be approximately 10 minutes after the 3 blinks. If applicable, you should abort the dive as fast as possible and turn the lamp off (reduce the power setting).



Further use of the lamp will increase the wear and tear on the cells and reduce their life expectancy.

DISCHARGE WARNING



Warning !

At the latest, the lamp should be turned off and no longer operated when it starts to blink continuously. Further use of the lamp will damage the cells and should only be practised in an emergency.

The duration of blinking with the standard halogen bulb set at 100% power is approx. 1-2 minutes. If the lamp is switched over to 25% power, then approx. 3 minutes of continuous light is available. After this, the light will go into a blinking mode once again.

DISCHARGE PROTECTION



Warning !

The discharge protection will turn shut down the lamp after the continuous blinking. In the case of an emergency where light is necessary, the lamp (if possible after a short pause) can be reactivated and will automatically turn on at 25% power setting. The cells are almost certainly damaged should this mode of operation be selected.

If the blinking stops or if the light becomes visibly weaker and has a yellow tint, then there is probably an error in the electronics. Stop operating the lamp as soon as possible and return it to the manufacturer for evaluation/repair.

Due to the previously mentioned risks of damage to the cell pack as a result of severe discharge, the lamp should never be operated without constant supervision and control.

TEMPERATURE MONITORING AND WARNING

During operation, the electronics constantly monitor the temperature of the cells. If the temperature exceeds 60°C (140°F), a warning will be generated and the LED display will begin to blink quickly (4 x per second) and the power of the lamp will automatically reduce to 25%. If this occurs, shut off the lamp and allow it to cool down (unless in an emergency situation where the lamp is necessary).

Return the lamp to the manufacturer for evaluation.

If this function does not activate, a secondary monitoring will shut down the lamp (halogen bulb and LED display) at 75°C (167°F). In this case, the lamp cannot be operated any more. Return the lamp to the manufacturer or replace the cell pack with a new unit.

WATER INGRESS WARNING

If a substantial amount of water enters the lamp and reaches the power pack circuit board, a warning will be generated; the LED display will begin to blink quickly (4 x per second) and the power of the lamp will automatically reduce to 25%.

**Warning!**

Terminate the dive following standard safe diving practices and open the housing as soon as possible.

An extended period of flooding, in particular salt water flooding, may cause a failure of this warning function.

OVER PRESSURE WARNING

If the pressure inside the housing increases (e.g. as a result of gas production due to electrolysis after flooding and/or if the cell(s) are defective), an over pressure indicator in the form of a small plug located to the left of the LED display will protrude approx 6mm (1/4") from the housing. The LED display will begin to blink quickly (4 x per second) and as a safety precaution the power of the lamp will automatically reduce to 25%. Turn off the lamp as soon as possible.

**Warning!**

Terminate the dive following standard safe diving practices and open up the housing as soon as possible, (see page 22).

AFTER USE**Warning!**

After the dive is completed, examine the lamp for signs of flooding or water ingress as soon as possible. To carry out this check, hold the lamp upside down with the glass plate pointing down and look at the glass plate from the side for any signs of moisture/water ingress.

After each use, the lamp should be thoroughly rinsed in clean, fresh water. During this rinsing, operate the switch in all directions to rinse under the switch.

When the lamp is operating, the temperature in the housing will increase and a slight overpressure will form inside the housing. If the housing is opened immediately after use, this slight overpressure will cause excessive friction on the threads of the covers and/or the O-ring seals, the cover will be difficult to open. For this reason we recommend that the lamp is left unopened (unless flooding has occurred) for several minutes after it is switched off.

TRANSPORT

After use, the switch should be locked in the off position to prevent inadvertent operation/use. To lock the switch in the off position, push the switch towards the LED display, it should click into the transport lock position. When correctly locked, the switch cannot be pushed to the left or right.

**Warning !**

If the lamp is to be transported or stored without direct supervision, the halogen bulb must be removed from the socket and stowed (see page 9). This is a precaution in case a defective electronic module turns the lamp on. This heat generated by the halogen bulb may cause damage to items adjacent to the lamp/glass/bulb.

STORAGE

For extended periods of storage, the cell pack should be removed, the halogen lamp removed from the socket and stowed and the housing should be closed. Place the cell pack on a suitable surface (non sensitive) and store in a dry environment between 10° - 20°C (50 – 68°F). Under no circumstances should the lamp be subjected to temperatures above 45°C (110°F). If a cell pack is continuously stored at full charge and increased temperatures, the cell pack will suffer from an irreversible reduction of capacity of more than 10% per year.

If the cell pack is to be stored for an extended period of time, the cell pack should be stored at a low temperature with a capacity of 50-60%.

The irreversible loss of capacity due to natural loss of capacity over time can be reduced to as little as 3% with good care and attention. The lithium manganese cells are subject to a very small natural discharge (depending on the ambient temperature this is approx. 4-8% per month, and the electronic in the lamp that monitor the conditions result in approx. 3% discharge per month).

If the cell pack is stored for extended periods of time, it should be recharged every 4-6 months to approx. 50-60% capacity.

A completely discharged cell pack is protected by the electronic monitoring that prevents further charging. In this case, return the cell pack to the manufacturer for evaluation.



CHARGING

GENERAL INFORMATION CONCERNING CHARGING RE-CHARGEABLE CELLS

The **lithium manganese re-chargeable cells** used in this lamp have been declared as gas and acid/alkali sealed. For this reason the electrolyte in the cells cannot escape and the cells can be charged regardless of their environment. This positive feature has been stated by the cell manufacturer but an exception to this cannot be ruled out.

Re-chargeable cells can, if defective, produce an internal pressure in the cell during charging/discharging (use) that may cause the over pressure device integrated in the cell to open. This in turn will allow electrolyte to escape from the cell. Electrolyte is an aggressive alkali and also conducts electrical current, this will destroy the cell over time. The resulting electrolysis will create an over-pressure inside the housing of the lamp.

Warning !



In case of a defective cell, the lamp is equipped with a mechanical and electronic over pressure indicator. After charging the lamp with the housing closed, check these indicators and ensure that there is no over pressure inside the housing. (see page 15).

MEMORY-EFFECT

The so-called memory effect will occur when re-chargeable cells are regularly charged in a partly discharged state (for example this occurs when a wireless telephone is placed in the charging station every evening). The popular rule of thumb to only charge re-chargeable cells when they are completely discharged is applicable to NC (nickel cadmium) or NMH (nickel metal hydride) cells. This rule does not apply to underwater lamps with high discharge currents, in this case, the regular full discharge has a negative effect on the cells. The lithium manganese cells used in this lamp do not have a memory effect.

Warning !



Regularly discharging a multi cell power pack may damage the voltage

features of individual cells within the cell pack, thus causing an unbalance within the cell pack that in turn may cause the weakest (and therefore the most susceptible) cell to fail prematurely. The more often the cell pack is discharged to the point where the discharge protection cuts in, the greater the chance that an individual cell will fail within the cell pack.

PREPARATION FOR CHARGING

There are two methods for charging the lamp.

I. INTERNAL CHARGING CONNECTION

The charging connection is located on the cell pack, the cell pack must be removed for charging.

This is the preferred method of charging as the cell pack can be seen and monitored during the charging process.

Open the rear cover on the lamp housing and remove the power pack (see page 10).

The charging connections are marked with + (red/right contact) and – (blue/left contact).

Charge the cell pack in a cool dry environment (ideally 10-20°C / 50 – 68°F). The ambient temperature should never exceed 40°C (104°F). If the cell pack is warm to touch (above 40°C / 104°F) then allow the cell pack to cool down before charging.

Warning !



The charging process requires a mains power supply socket close to the cell pack and the cell pack should be placed on a dry surface that is not sensitive. (Even gas tight lithium manganese cells may leak under certain conditions, this leakage may cause damage to the surface the cell pack is placed on).

Note that a defective electronic module may cause the lamp to turn on during charging. Damage to adjacent material caused by the resulting heat generated by the halogen bulb must be avoided. For this reason we recommend that the halogen bulb is removed during charging.

Warning !



Check the condition of the charging sockets and cell pack regularly and examine for signs of corrosion, oxidation or leakage. Examine the sleeves surrounding the cells for signs of bubbling or traces of a white, floury residue between the cells in the cell pack. In any of the above conditions are found, do not charge the cell pack ! Return the lamp to the manufacturer for evaluation, pack the cell pack and the housing separately.

Warning !



The temperature of the individual cells should also be checked regularly by feeling the temperature during charging. If one or more cells is hot to touch then this may indicate a defective cell or cell pack. Do not use this cell pack, return it to the manufacturer for evaluation or replace the cell pack with a new one.

II. EXTERNAL CHARGING CONNECTION

The charging connection is on the outside of the housing, the cell pack remains in the lamp housing during charging.

This method of charging is advantageous when the ambient conditions are unsuitable for opening the housing, the cell pack is charged via the external connections located on the rear of the housing.

The charging connections are marked with + (red/right contact) and – (blue/left contact).



Because the cell pack cannot be examined whilst using this method of charging, we recommend that it should only be carried out in exceptional circumstances. After the lamp has been charged repeatedly using the external charging connections, the cell pack must be examined for signs of damage/deterioration !

Before the plugs are plugged into the charging connections, the sockets must be thoroughly cleaned and dried (e.g. with an air blast or with a Q Tip). Moisture can lead to oxidation and/or charring of the connections during charging.

The ambient temperature should not exceed 40°C (104°F) during the charging process. If the lamp has been in direct sunlight and is warm to touch (above 40°C / 104°F) then cool the lamp down before charging.

Warning !

The charging process requires a mains power supply socket close to the cell pack and the cell pack should be placed on a dry surface that is not sensitive. Note that a defective electronic module may cause the lamp to turn on during charging. Damage to adjacent material caused by the resulting heat generated by the halogen bulb must be avoided.

MONITORING DURING CHARGING

The control module in the lamp monitors the temperature of the cell pack during charging. If the temperature of the cell pack exceeds 60°C (140°F) during charging, the charge process will be automatically stopped and the LED display will blink (4 x per second).

INDICATIONS ON THE LED DISPLAY DURING CHARGING

When the lamp is being charged using the external charging connections, the LED display will show the current capacity status of the cell pack. The actual charging process is indicated by the last LED blinking approx 2 x per second. When the cell pack is fully charged, the electronic module automatically shuts off the charger and all 4 LEDs are off. Within 1 hour, the electronic module will re-start the charging process approx 2 or 3 times to „top-up“ the cell pack to the max. capacity (approx 2-3% top-up charge).

NON-ORIGINAL CHARGERS

Warning !



Only chargers that have been approved by the manufacturer in advance of use may be used for charging the lamp. Using non-approved chargers, voids the manufacturer's warranty.

Use of non-original chargers may damage the electronic module that monitors the cell pack condition. The cells can overheat and/or be damaged. (Risk of explosion !).

Use of chargers that are not previously approved by the manufacturer is an alteration to the original design.

This voids the warranty and any releases the manufacturer of any responsibility and liability for subsequent damage and/or injury.

CHARGER OFF-SHORE I/6



Use only manufacturer approved cells, do not connect any non-approved cells.

The charger off-shore 1/6 is suitable for charging the High-Tech-mini lamp nano compact.

The max. charging current is approx. 1.1 Amps.

The charging time for the nano compact is approx. 3 hours.

The charger uses the latest technology with a wide range input voltage rating and accepts any voltage between 100 and 250V and frequencies between 45 and 65 Hz. It is not necessary to mechanically pre-select the local voltage. All Hartenberger cell packs with 5-6 cells (6 – 7.2V) are identified by the charger when connected and will have an optimal; efficient charge.

When charging the nano compact lamp, the cell pack monitoring is carried out by the electronic module in the cell pack.

First connect the charging cable to the charger using the chinch plug. The charging cable is plugged into the charging sockets on the lamp with banana plugs. When connecting the cable(s) to the lamp and/or charger, guide the plugs straight into the sockets and do not use excessive force. Ensure the correct plug is connected in to the charging socket, follow the colour coding and labelling (red/+ on the right, blue/- on the left)

The charger is initiated when the mains is connected (plugging the charger into the mains socket). The charger is equipped with a standard euro 2 pin flat plug. Other popular plug configurations are available and replace the euro plug simply by pulling it out and fitting the plug desired.

Avoid short circuiting the plug pins (e.g. with a metal object crossed over the two pins). Ensure the charger is dry and away from moisture and the cooling slots are not covered or restricted particularly in extreme climates/conditions.

All the functions of the charger are displayed via a single LED.

Charger LED when charging NC or NMH re-chargeable cells:

Red	Mains power is connected, cell pack is charging.
Off	No mains power or no cell pack connected.
Red blinks slowly	Mains power connected, cell pack is fully charged and a trickle charge is active.
Rot blinks fast	Mains power connected, the cell pack is fully discharged and is being regenerated by the charger.

If fully discharged cell packs are connected, the LED will blink red very fast (approx. 3 x per second). Stop the charging process after approx. 5 minutes by isolating the mains power. Resume the charging process after approx 3 minutes. If the charger repeatedly blinks fast on re-starting the charging process, the cell pack is probably defective and can/should not be charged).

Charger LED when charging lithium manganese re-chargeable cells:

When the cell pack is fully charged (all 4 LEDs on the nano compact display of off) the electronic module in the lamp will cut off the charging current to the lamp. The charger LED is off or may blink irregularly.

CHARGER OFF-SHORE II

Use only manufacturer approved cells, do not connect any non-approved cells.

The charger off-shore 1/6 is suitable for charging the High-Tech-mini lamp nano compact.

The max. charging current is approx. 1.8 Amps.

The charging time for the nano compact is approx. 2 hours.

The charger uses the latest technology with a wide range input voltage rating and accepts any voltage between 100 and 250V and frequencies between 45 and 65 Hz. It is not necessary to mechanically pre-select the local voltage. All Hartenberger cell packs with 5-12 cells (6 – 14.4V) are identified by the charger when connected and will have an optimal efficient charge.

When charging the nano compact lamp, the cell pack monitoring is carried out by the electronic module in the cell pack.

First connect the charger to the mains by plugging in the mains cable. All the functions of the charger are displayed via 2 LEDs. The charger is monitored by a special electronic module inside the charger. This module requires 1-1.5 seconds to carry out a self test after which time the LEDs will illuminate.

Charger LEDs when charging NC or NMH re-chargeable cells:

LED I :

Green	Mains supply connected, charger is functioning correctly.
Red	Mains supply connected, charger is overloaded or defective.
Off	No mains supply connected.

Next connect the charging cable to the charger using the chinch plug. The charging cable is plugged into the charging sockets on the lamp with banana plugs. When connecting the cable(s) to the lamp and/or charger, guide the plugs straight into the sockets and do not use excessive force. Ensure the correct plug is connected in to the charging socket, follow the colour coding and labelling (red/+ on the right, blue/- on the left)

Avoid short circuiting the plug pins (e.g. with a metal object crossed over the two pins). Ensure the charger is dry and away from moisture and the cooling slots are not covered or restricted particularly in extreme climates/conditions.

LED II :

Red	No cell pack connected (pause).
Green blinks	Fast charge to 100 % of the cell pack capacity.
Off	Trickle charge, cell pack is 100% charged.

Charger LED when charging lithium manganese re-chargeable cells:

When the cell pack is fully charged (all 4 LEDs on the nano compact display of off) the electronic module in the lamp will cut off the charging current to the lamp. LED II on the charger will be red (cell pack not connected) or may blink irregularly

CARE AND MAINTENANCE

HOUSING

We recommend that from time to time the housing surface is impregnated with silicone. The chance of calcium depositing on the surface of the lamp is reduced and the scratch resistance properties of the housing surface are also improved. (Action to be taken Interval By Owner)

Action to be taken	Interval	By Owner	Workshop
Examine wrist strap / hand line for integrity/damage	Before each use	X	
Examine the O rings and sealing surface of the end covers for damage, contamination and/or deterioration, clean and lubricate as necessary	Every time the lamp housing is opened latest after 6 months or 50 times use	X	
Replace the O rings in the covers	Every 12 months or earlier if damaged	X	
Clean and dry external charging connections	Before each external charge	X	
Rinse under and around the switch with fresh water while moving the switch	After each dive	X	
Impregnate the housing with silicone grease	After several uses as necessary	X	
Replace the O rings under the rear cover (charging connections/pressure over pressure indicator)	Every 500 dives or every 5 years at the latest		X
Replace the O ring in the front cover (glasses)	If damaged / deteriorated or every 5 years at the latest		X
Replace the halogen bulb	Life expectancy approx 100 hours	X	
Replace cell pack	Life expectancy up to 500 operating hours	X	

SERVICE LOG O RING / HALAOGEN BULB REPLACEMENT

O-Ring 48x3,0 Glass plate	O-Ring 40x3,0/48x1,6 front cover	O-Ring 40x3/48x1,6 rear cover	Halogen bulb
Notes:			

FAULT DIAGNOSIS

Problem	Cause	Action to be taken
<p>* Water enters the housing: (see below for specific problem)</p> <p>1. Fresh water</p> <p>2. Salt water a few drops</p> <p>3. Salt water flooding</p>	O rings or sealing surfaces defective or contaminated	<p>Break off the dive as soon as possible, open the lamp and unplug the cell pack from the electronic module !</p> <p>1. Dry all components, pack them separately and return the lamp to the manufacturer for evaluation</p> <p>2. Dry all components, pack them separately and return the lamp to the manufacturer for evaluation</p> <p>3. Rinse all components in fresh water, dry and pack them separately and return the lamp to the manufacturer for evaluation</p>
Housing covers difficult to screw on/off	<p>1. Housing cover and/or O ring contaminated or insufficiently lubricated</p> <p>2. Damaged thread</p>	<p>1. Clean and lubricate the cover and O ring</p> <p>2. Return the lamp to the manufacturer for repair</p>
Lamp does not turn on	<p>1. Cell pack is discharged</p> <p>2. Bulb is defective</p>	<p>1. Charge the cell pack</p> <p>2. Replace bulb</p>
Charging LED does not illuminate during charging	<p>1. Cell pack is charged</p> <p>2. Charging cable incorrectly connected</p> <p>3. Loose contact between mains plug and charger</p> <p>4. No mains power</p>	<p>1. Check capacity</p> <p>2. Connect charging cable correctly</p> <p>3. Check correct fit of mains plug</p> <p>4. Check power supply</p>

*** Warning !**

Danger of explosion when moisture enters the lamp housing !
When water enters the inside of the lamp, the resulting oxidation can generate an over pressure inside the housing (over pressure indicator and/or blinking LED).

Never look onto the glass plate directly. An increase in pressure inside the housing can cause the glass plate to be pressed out of it's mount.

If the covers of the lamp cannot be opened, the rear plastic cap on the housing must be removed. Remove the two decals and remove the 4 screws with a suitable screwdriver.

Attention; the over pressure indicator requires excessive force for removal. Under certain circumstance, electrolyte may be forced out of the housing (risk of injury/burning/scalding)

SPARE PARTS

Bulb	Power Output	Socket	Expected life
Halogen Bulb HLX	6V/10W	G 4	ca. 100 h
Halogen Bulb HLX	6V/20W	G 4	ca. 100 h
Halogen Bulb	6V/35W matt*	G 4	ca. 2000 h

*Halogen bulb with a matt glass cover. Only use in combination with the flood reflector (e.g. for video lighting) This bulb is not as efficient as a normal bulb and subjectively has a similar brightness to the 20W bulb, this is because the increased brightness is spread over a wider area.

O-Ring	Dimensions (mm)	Hardness (Shore)	Material
Glass	48 x 3,0	60°	Viton blue
Screw Fitting	40 x 3,0	50°	Viton blue
Screw Fitting	48 x 1,6	50°	Viton blue

ACCESSORIES

NEOPRENE SLEEVES NANO COMPACT

Neoprene sleeves for the housing offer protection and a reduction in weight in the water and are available in the colours yellow and black.

TRANSPORT BAG NANO COMPACT

Nylon bag, offers protection whilst transporting the lamp in diving gear bags.

TRANSPORT BAG CHARGER

Nylon bag, offers protection whilst transporting the charger in diving gear bags.

CARABINER CLIPS

For securing the lamp to a suitable point on the diving equipment.

CARABINER WITH SPIRAL CABLE

Allows the lamp to be used within the length of the spiral cable whilst always secured to the diving equipment

SPOT REFLECTOR MODULE (STANDARD)

Reflector unit with a narrow beam angle for general illumination applications.

FLOOD REFLECTOR MODULE (OPTIONAL)

Reflector unit with wide angle of illumination and mattes front glass plate for photo, video and film applications.

LED-MODULE (OPTIONAL)

LED-Module (4x3,5 watt, spot beam) ideal for diving in fresh water and low light environments.

REPLACEMENT CELL PACK

Replacement nano compact 7,2V/3,8Ah Cell pack with lithium manganese cells for quick replacement of a discharged cell pack.

Do not throw defective/unwanted cell pack in the normal waste, dispose of them correctly at a suitable recycling point.

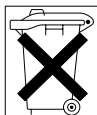

Hartenberger

*Unterwassertechnische Geräte GmbH
Rennebergstr. 19 D - 50939 Köln
Germany*

*Tel.: +49 221 415000
Fax.: +49 221 415050
info@hartenberger.de
www.hartenberger.de*