

Instructions for use

Hartenberger

High – Tech Hand Lamp

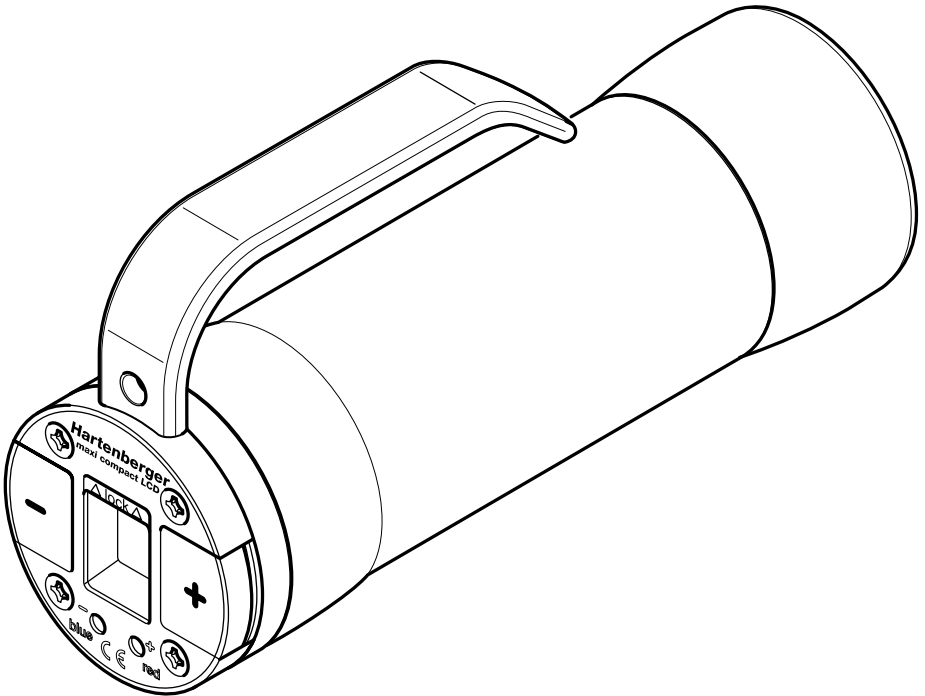

maxi compact LCD

CONTENTS

WARNING SIGNS	2
SAFETY WARNING	3
GUARANTEE	3
APPLICATIONS.....	3
ARTICLE DESCRIPTION HOUSING	4
ARTICLE DESCRIPTION CELL-PACK	6
TECHNICAL SPECIFICATIONS.....	7
FRONT SCREW FITTING	8
REAR SCREW FITTING.....	9
BULB/LED	10
POWER PACK	11
PREPARATION FOR USE	12
USING THE UNDERWATER LAMP	12
AFTER EACH USE.....	18
TRANSPORT.....	18
STORAGE	18
CHARGING	19
CHARGER OFF-SHORE I/12.....	22
CHARGER OFF-SHORE II.....	23
CARE AND MAINTENANCE	24
FAULT DIAGNOSIS	26
SPARE PARTS.....	27
ACCESSORIES.....	27

WARNING SIGNS

If the sections of these instructions for use marked with the above warning sign are not adhered to, there is a danger of damage to property, personal injury.



Warning !

If the sections of these instructions for use marked with the above warning sign combined with the word "Warning" are not adhered to, there is a *considerable* danger of damage to property, personal injury or even death.

SAFETY WARNING**Warning !**

Before attempting to use the underwater lamp, carefully read and adhere to these instructions for use.

The use of the underwater lamp maxi compact LCD calls for the same amount of care and conscientiousness as is necessary in order to practice diving in a safe manner. If the instructions are not followed, there is a great danger of personal injury as well as injury to property (danger of explosion).

GUARANTEE

If these instructions for use and the care and maintenance guidelines are adhered to, we will guarantee all mechanical parts made from steel, aluminium, glass and plastic for a period of 5 years against manufacturers defects and material failure. All electronic parts are guaranteed for a period of 2 years. The rechargeable cells have a guarantee against manufacturers defects and material failure for 6 months. If the accumulators are dealt with and handled correctly (see page 12ff), they are covered by our 2 year guarantee. Halogen bulbs and O-ring seals are expendable items and are therefore not covered by the guarantee. Any unauthorised work on the lamp, i.e. the removal or tightening of screws, or the removal of the guarantee seals, will make the guarantee invalid.

Warning !

The manufacturer's warranty expires if these instructions for use are not followed and strictly adhered to. If the lamp is tampered with or dismantled in part or full by an unauthorised workshop or technician, the warranty automatically expires, such tampering includes but is not limited to; loosening and/or tightening screws, the removal/damage of original seals. When purchasing the lamp make sure that the original manufacturer's seals are intact (1x housing electronics, 1 x cell-pack electronics, charger off-shore II).

Warning !

If the lamp is tampered with and/or if unauthorised (from the manufacturer) parts/components (e.g. cells, electronics components, non-original chargers,) are used or installed in the lamp, this results in a change of original design and the warranty is automatically invalid. The manufacturer is also released from any product liability.

APPLICATIONS**Warnings**

The *maxi compact LCD* underwater lamps are for use in underwater lighting applications.

Using the lamp in an environment other than water can lead to an overheating and consequently to a danger of explosion.

In special cases please ask the manufacturer for release.

ARTICLE DESCRIPTION HOUSING

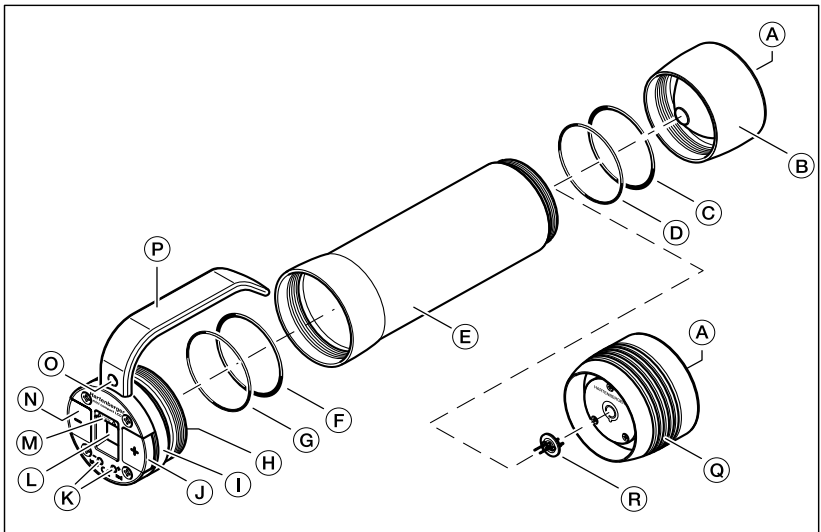

Fig. 1: housing

- (A)** FRONT SEAL / FRONT GLASS PLATE
The front glass plate with the O-Ring (58 x 3.8 60° hardness) is pressed into the housing during the assembly by the manufacturer. It can only be opened by an authorised workshop.
- (B)** FRONT COVER (REFLECTOR COVER)
The standard front cover is equipped with a spot reflector for use with halogen bulbs. Flood reflectors and/or chemically matt coated front glasses are available as options.
- (C)(D)** O-RINGS
48 x 3,0 and 48x1,6 mm 50° hardness.
- (E)** HOUSING / BODY
The housing / body is sealed with the front and the rear screw fitting.
- (F)(G)** O-RINGS
48 x 3,0 and 48x1,6 mm 50° hardness
- (H)** PLUG-IN CONNECTION
The plug-in connection serves as an electrical and mechanical connection between the power pack and the electronic control panel.

- ① REAR HOUSING COVER
The rear housing cover can be removed for accessing/removing/replacing the cells pack and/or the halogen bulb.
- ② ③ BUTTON PAD (SWITCHES + AND -)
The – (left) and + (right) switches select all the electronic controls and features.
- ④ CHARGING CONTACTS
The charging contacts are for charging the cell pack while the housing is closed. The contacts are colour coded: +/red (right contact) and -/blue (left contact).
- ⑤ LCD DISPLAY
The LCD display shows the current programme mode, the state of charge of the cells, the current power setting and the resulting remaining burn time. The serial number, date of manufacture and more can also be viewed in the LCD Display.
- ⑥ TRANSPORT LOCK
When the transport lock is pushed up in the lock position, the operating switch is protected from inadvertent operation.
- ⑦ HOLE FOR A LANYARD
The hole in the handle provides an attachment point for a lanyard for better security during use and may prevent loss of the lamp..
- ⑧ HANDLE
The handle provides a good hold on the lamp, even when wearing thick neoprene gloves or mittens. If required for video mounting, the handle can be drilled and an M8 thread cut for mounting to video rigs.
- ⑨ FRONT HOUSING COVER (LED-CONNECTION)
The front housing cover is also available with 7 x 3.5 Watt LED spots as an option.
- ⑩ PLUG MODULE FOR LED OPERATION
The LED plug module (G 6.35) is plugged in to the halogen bulb socket when the lamp is to be used with LEDs.

POWER PACK MEGA

Fig. 2: Cell-Pack

- Ⓢ HALOGEN BULB
The halogen bulb is pushed into a standard socket (Type G6,35) and can easily be replaced
- Ⓣ SPARE-O-RING
The O-ring (48 x 3,0 50° Hardness) is located in a groove in the power pack.
- Ⓤ SPARE-O-RING
The O-ring (48 x 1,6 50° Hardness) is located in a groove in the power pack.
- Ⓥ SOCKET
Socket for G6.35 Halogen bulb or the adapter plate for the LED module
- Ⓦ CELL PACK
The cell pack is plugged in to the power pack and can be removed/replaced in seconds. The cell pack consists of a Lithium Manganese (LiMn) cell block, a micro processor electronic and the socket for the halogen bulb.
- Ⓧ CONTACT PINS
The contact pins serve as an electrical and mechanical connection between the power pack and the housing electronic module and for charging the cell pack.

TECHNICAL SPECIFICATIONS

APPROX. BURN TIME IN MINUTES WITH LIMN CELL PACK 14,4V / 5,4AH

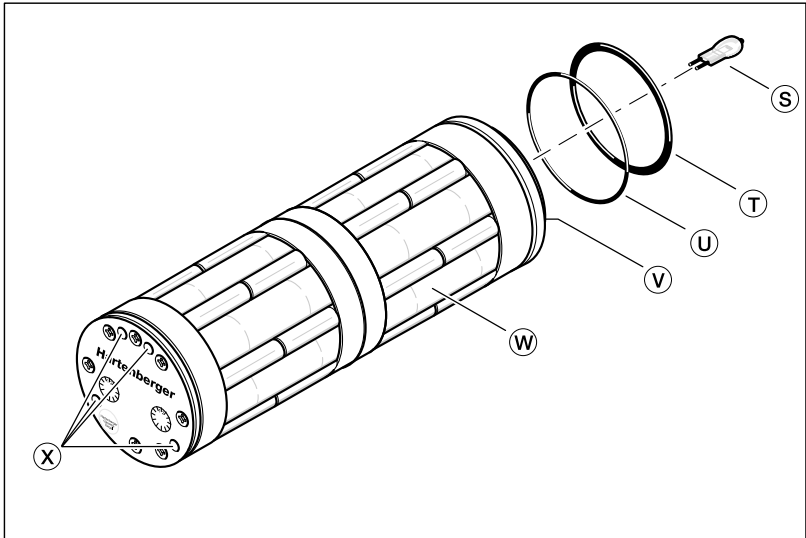
Halogen Bulb 12V	30W	50W	100W *	LED 7x3,5W
Time of use at 25%	520	200	160	430
Time of use at 50%	260	140	80	360
Time of use at 75%	200	120	60	235
Time of use at 100%	130	80	40	175
Time of use at 125%	100	60	30	140

The bold printed figures represent the burn times with the standard bulbs as supplied with the lamp from the manufacturer.

Halogen bulbs available in retail outlets often need up to 10% more power as stated. The stated burn times will therefore be shortened.

Low ambient temperature have little effect on lithium manganese cells. These special cells have approx 95% capacity in water temperatures between 0° and 5° Celsius (32° - 41° Fahrenheit).

A 3% - 10% reduction in performance over 12 Months can be regarded as normal life reduction.

DIMENSIONS/WEIGHT/PRESSURE PROOF

Length & Diameter	weight on land	weight in water	Resistance to water Pressure
240mm x 69mm	1.3kg	0.2kg	100m

FRONT GLASS PLATE

The maxi compact LCD lamps have a tempered borosilicat-glass plate as standard. This glass plate has a temperature shock resistance of 300°C (570°F). It is therefore possible to use the lamps above and under water. A rapid cooling of a heated front glass is no problem (for example if used temporarily above water in order to orientate oneself on the surface of the water).

FRONT HOUSING COVER

FRONT GLASS COVER

The O-ring (56 x 3,0 60° hardness) seals the front glass plate in the cover and is specially pressed into the cover by the manufacturer. This O-ring must be replaced every 5 years, or earlier if it shows sign of deterioration (such as cracking). This job may only be carried out by an authorised workshop.

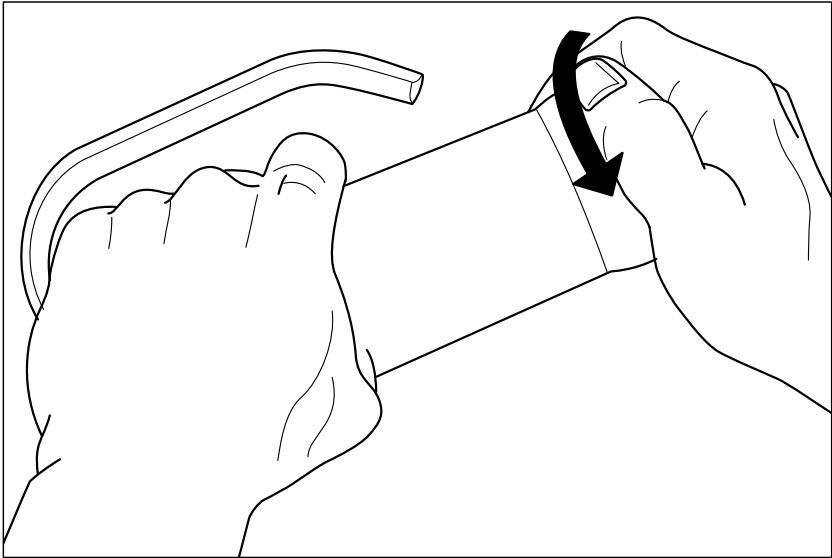

Fig. 3: Opening the front screw fitting

REMOVING THE FRONT HOUSING COVER

The front housing cover can be removed by unscrewing the cover anti-clockwise from the housing (thread length approx 10mm) see Fig. 3. To avoid damage to the halogen bulb, pull the front cover straight away from the housing.

CLOSING THE HOUSING

Before closing the housing, all threads, sealing surfaces and seals must be checked for integrity and cleanliness. Should the sealing surfaces and/or components be contaminated, then the O-rings (48 x 3,0 50° hardness and 48 x 1,6 50° hardness) and its groove should be thoroughly cleaned. Should the sealing surfaces and/or components be damaged, then all damaged parts should be replaced. If the O-ring is removed, care must be taken not to damage the groove in which the O-ring sits. A soft blunt tool should be used for the removal of the O-ring, i.e. a wooden tooth pick. Before the components are refitted it is recommended that a thin coating of silicone grease is applied as lubrication. It is recommended that after such work has been carried out, that the seal/integrity of the housing is first checked underwater without the power pack fitted. The housing is then closed by screwing the components clockwise together. The screw fitting should be tightened by hand only until the parts are mated together.

REAR HOUSING COVER (THREADED CAP)

THE REAR HOUSING COVER SEALS

The double O-ring seals on the charging socket and the display can only be replaced by the manufacturer.

Based on the experience gained to date, this service work should be carried out every 5 years. Our experience with other models indicates that these seals are in good condition after this period.

Please get the latest information from our web site

(http://www.hartenberger.de/pdf/e_bet_maxilcd.pdf) on service intervals and recommended life spans the can change with time/experience.

The plastic components on the rear housing cover should not be exposed to any solvent based agents, such exposure may result in cracks in the components and subsequent leakage/flooding.

OPENING THE REAR SCREW FITTING

The housing is opened by unscrewing the fitting anti-clockwise, (thread length approx. 10 mm [3/8"]). Whilst opening the housing, it should be held in an upright position, thus preventing the power pack from inadvertently falling out.

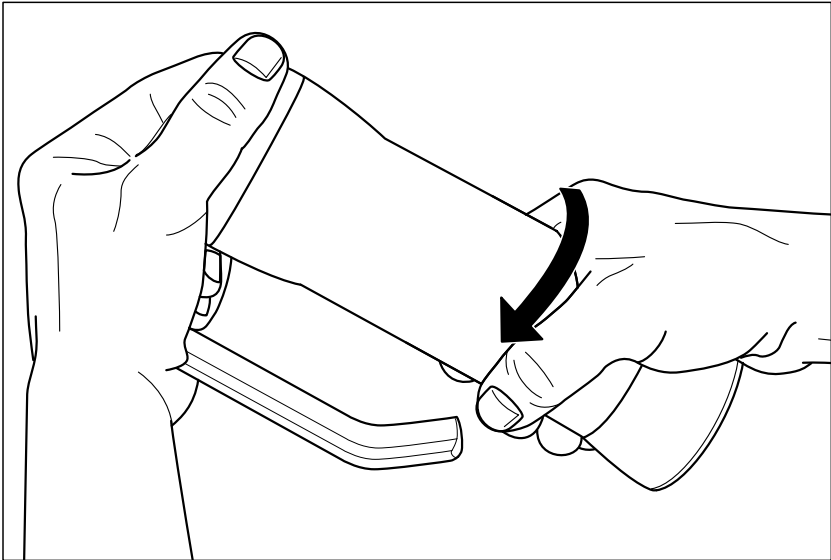

Fig. 4: Opening the rear screw fitting

CLOSING THE REAR SCREW FITTING

Before closing the rear screw fitting, all threads, sealing surfaces and seals must be checked for integrity and cleanliness. Should the sealing surfaces and/or components be contaminated, then the O-rings and its groove should be thoroughly cleaned. Should the sealing surfaces and/or components be damaged, then all damaged parts should be replaced. If the O-ring (48 x 3,0 50° hardness and 48 x 1,6 50° hardness) is removed, care must be taken not to damage the groove in which the O-ring sits. A soft blunt tool should be used for

the removal of the O-ring, i.e. a wooden tooth pick. Before the components are refitted it is recommended that a thin coating of silicone grease is applied as lubrication. It is recommended that after such work has been carried out, that the seal/integrity of the housing is first checked underwater without the power pack fitted. The housing is then closed by screwing the components clockwise together. The screw fitting should be tightened by hand only until the parts are mated together.

BULB/LED

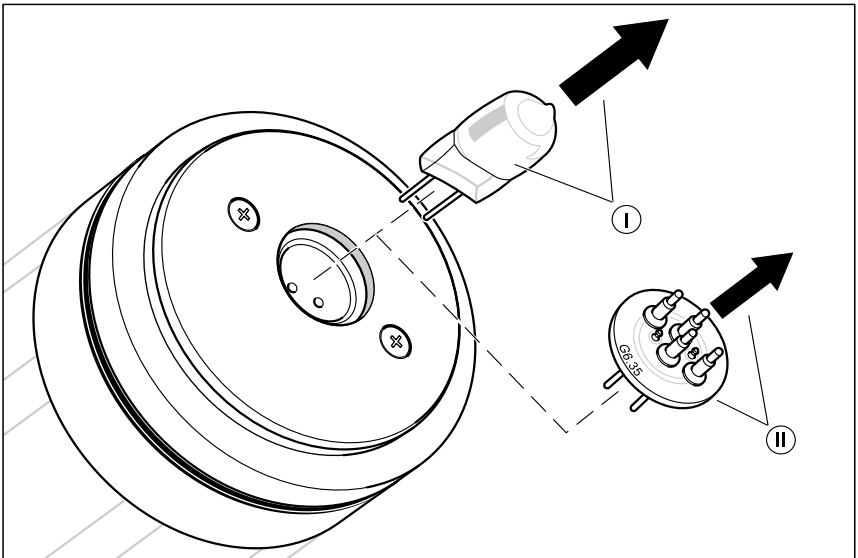

Fig. 5: Removal/Refitting the bulb

REMOVAL/REPLACEMENT OF THE HALOGEN BULB

After removing the front or rear cover, the halogen bulb can be removed and/or replaced

RISK OF INJURY THROUGH BURNING !

The halogen bulb remains very hot for an extended period of time after use! Do not touch the halogen bulb with your bare fingers. Residue on your fingers can remain on the glass during normal use may form carbon. This will reduce the efficiency of the bulb. Use a clean cloth or tissue to remove the bulb from the socket (see fig. 5, I). When refitting or replacing the bulb, ensure that it is located all the way into the socket. To produce an even illumination, it is imperative to ensure that the bulb sits upright in the socket. Assemble the lamp and check for correct fit and operation. If the light beam is uneven or the beam is not focused correctly, the halogen bulb can be extracted from the fully inserted position in the socket approx. 1mm.

To prevent plastic components and the cells of the lamp from overheating and becoming damaged by heat, the halogen bulb should only be switched on when the housing is completely assembled and all covers are screwed tight.



MAINTENANCE OF THE REFLECTOR

If the reflector mirror becomes dirty or is contaminated, it must be cleaned with a soft, dry cloth. Remove the front housing cover and then the reflector can be removed. First remove the O-ring (\varnothing 3mm, 50° hardness) using a blunt tool such as a tooth pick or similar, care must be taken not to damage the O-ring. Once the reflector has been cleaned, the O-ring can be refitted into the groove between the reflector and the housing cover, make sure the O-ring sits correctly into the groove, a blunt tool can be used for pressing the O-ring into the groove.

LED MODULE (optional)

The optional LED-Module (Light-Emitting -Diodes) replaces the standard halogen bulb and front cover/reflector. The module is connected electrically by plugging the G6.35 connector into the halogen bulb socket. (see fig. 5, II). The electronic arrangement prevents incorrect fitting/connection. If the lamp does not function properly, remove the plug module, rotate it 180° and refit it into the halogen bulb socket. Take care not to short circuit the contacts.

If an LED module with poor heat radiation is installed, the LEDs are in danger of overheating and the performance will automatically be reduced to approx. 25%.

POWER PACK

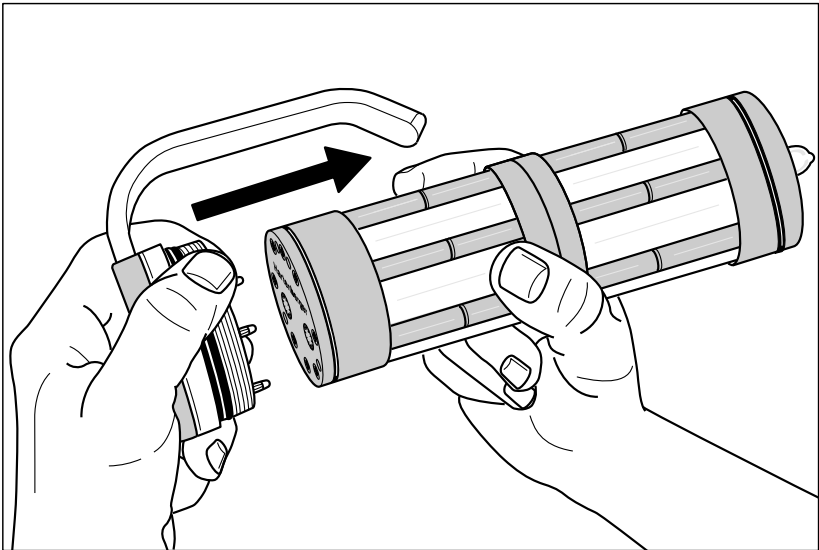

Fig. 6: Removal of the power pack

REMOVING THE CELL PACK

After removing the rear housing cover (see page 9), the complete cell pack can be unplugged and removed (Fig. 6).

The 4 pins serve as the mechanical and electrical connection between the cell pack electronics and the housing electronics.

FITTING THE CELL PACK

Hold the rear housing cover upwards and carefully plug the cell pack onto the rear housing cover. Ensure that the 4 plugs on the rear housing cover are guided into the sockets carefully. The plug arrangement prevents incorrect connection. Push the cell pack fully down on to the pins without damaging/distorting the pins and without use of excessive force.

PREPARATION FOR USE

BEFORE THE LAMP IS USED FOR THE FIRST TIME

Before the first use, the cells must be charged. Hartenberger underwater lamps are manufactured to a high degree of precision and each lamp is tested to a water pressure of 10 bars. The condition of the lamp and in particular the housing and sealing rings should however be checked before the first use (see page 8).

Warning !



Due to damage during transportation or hidden material defects, leakage can occur (not the fault of the manufacturer). To check if the housing is pressure tight, the first dive should be carried out without the housing insert, i.e. empty.

BEFORE EACH USE

If the bulb has been removed for transport, it should be refitted into the socket (see page 10) or the LED module with the adapter plate for the G6.35 Socket must be fitted (see page 11).



Before each use, the front threads, sealing surfaces and O -Ring must be checked for integrity and cleanliness. (See Closing the housing Page 8ff.).

We recommend therefore that the cells are charged to 100% before each use.

USING THE UNDERWATER LAMP

TRANSPORT LOCK

Only release the transport lock to the unlocked position immediately before use. (See page 13). To unlock the transport lock, slide the screen down. The mechanism should click into the unlocked position.

Warning !



When the lamp is turned on, direct the beam away from yourself and others. Do not point the beam directly at others. If there is a defect on the lamp, the front glass plate may be forced out of the front of the housing with explosive force.

Warning !



Water inside the housing (especially sea water) can have drastic results consequences after some a period of time. There is a moisture sensor in the *maxi compact LCD*. If moisture is detected inside the housing the lamp will blink continuously and rapidly at 25% power. Abort the dive immediately following safe diving practices and open the housing as soon as possible after exiting the water (see page 26).

LCD DISPLAY

When the lamp is switched off, the lower portion of the LCD display will show the charge status of the cells as a percentage (%).

When the lamp is switched on, the display background light is activated and the power setting of the light is shown as a percentage (%) in the upper portion of the

display.

The remaining burn time is shown in minutes in the lower portion of the display. The display background lighting switches off automatically shortly after the lamp is switched off. The display lighting can be activated by pressing the – button or by switching on the lamp using the + button.



Warning !

The remaining burn time shown in the display is calculated as accurately as technically possible including consideration of the self discharge of the cells. When planning the dive, a certain degree of safety should be included rather than relying on the remaining burn time shown on the display. When the lamp is fully charged, the display has the highest accuracy.

SWITCH UNIT

The switch electronics and the power pack are both controlled by microprocessors. This provides a large range of features and functions. A large emphasis has been placed on simple, user -friendly intuitive operation. The entire electronics are controlled via two switches, left minus (-) and right plus (+).

The lamp is delivered with a comfort operation mode. The brightness can be adjusted in 5 equal steps from 25% to 125%. Pressing the + button for approx. ½ second increases the brightness by 25%. Pressing the - button for approx. ½ second decreases the brightness by 25%. If the + button is pressed longer (approx. 1 second) the lamp will go to the maximum (125%) setting. If the - button is pressed longer (approx. 1 second) the lamp will switch off.

SOS-EMERGENCY SIGNAL

The electronic provides the facility to send an emergency signal SOS according to the Morse alphabet (3 x short, 3 x long, 3 x short). This is activated by pressing the + switch so long that the maximum power is selected, then keeping the + switch pressed for a further 4 seconds. After the SOS feature is selected, lamps in the B or C mode can adjust the power of the signal using the +/- switches. The remaining duration of the emergency signal is shown in the display and is approx. 2 -3 times longer than the continuous use remaining burn time of the halogen lamp being used. When the power pack is almost completely discharged, the brightness will be reduced. To deactivate the SOS signal, press the – switch for approx. 4 seconds.

This feature should only be used in an emergency. Should you require the SOS distress signal in an emergency, we recommend that the signal is turned off when the intensity of the flashing reduces, and to turn the SOS signal back on should help be sighted.

OVER-VOLTAGE / DIMMER

The HLX bulbs which we use have a much greater efficiency than standard halogen bulbs. Using a 12 cell power pack, we have a power supply of 14.4 volts. This allows the 12v bulb to be operated continuously with an over-voltage of approx. 13,6 volts. The electronics switch the bulb on slowly thus preventing the coil in the bulb from burning out. The resulting increase in brightness is approx. 30% more than the stated power. The micro controller can accurately monitor the energy dissipation to the bulb and ensures a continuous colour temperature over the entire discharge process and operation. The life expectancy of the bulb of approx. 100 hours is not reduced. Using the lamp at reduced power settings saves energy and extends the burning time in a single charge cycle. Permanently operating the

lamp at reduced power settings will however produce a grey coating on the bulb's glass. If reduced brightness is required on an extended basis, then a lower power rating halogen bulb is recommended.

LOW LEVEL CAPACITY WARNING

When the lamp blinks 3 times, the user is warned of the immanent end of the burn time of the lamp. When the lamp is being used with the standard 50 watt halogen bulb at 100% power, this will be approximately 3 minutes after the 3 blinks. If applicable, you should abort the dive as fast as possible and turn the lamp off (reduce the power setting).

Further use of the lamp will increase the wear and tear on the cells and reduce their life expectancy.



DISCHARGE WARNING

Warning !

At the latest, the lamp should be turned off and no longer operated when it starts to blink continuously. Further use of the lamp will damage the cells and should only be practised in an emergency.

The duration of blinking with the standard halogen bulb set at 100% power is approx. 1-2 minutes. If the lamp is switched over to 25% power, then approx. 3 minutes of continuous light is available. After this, the light will go into a blinking mode once again.



DISCHARGE PROTECTION

Warning !

The discharge protection will turn shut down the lamp after the continuous blinking. In the case of an emergency where light is necessary, the lamp (if possible after a short pause) can be reactivated and will automatically turn on at 25% power setting. The cells are almost certainly damaged should this mode of operation be selected.



EMERGENCY MODE

Under certain unforeseeable circumstances such as extended periods of storage, high levels of self discharge or ageing of the cells, there can be a discrepancy between the remaining burn time in the display and the actual remaining burn time. In this case, the electronics will immediately recognise the imminent end of the burn time and that the display is showing an incorrect value. When the lamp is being used with a standard halogen bulb, the user will be warned by the lamp blinking 6 times and subsequently automatically switching over to 25% power. The remaining burn time is approx. 2 minutes. The display blinks continuously until the lamp is turned off.

If the lamp is fully charged within 20 hours of the emergency mode cutting in, the actual capacity of the cells is re-assessed and the display electronics are re-calibrated. The subsequent remaining burn times shown are again calculated the highest possible accuracy.

If the cells are not fully charged within 20 hours of the emergency mode cutting in, a re-calibration will not occur. The lamp should be calibrated by carrying out a reference cycle (see below).

WARNINGS

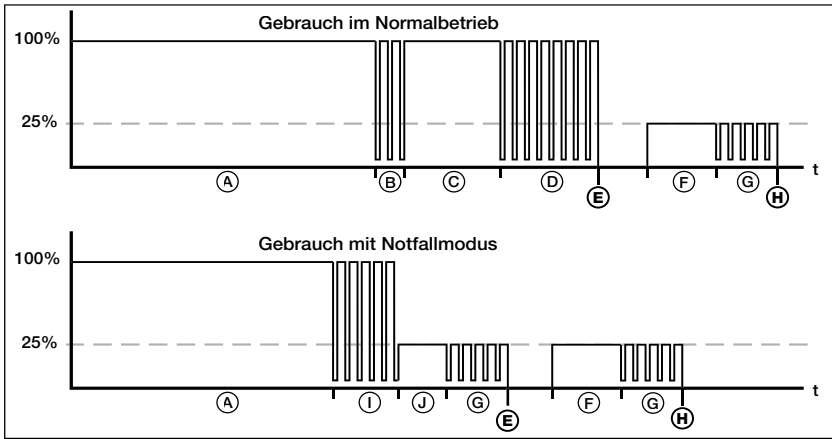

- Ⓐ Use with normal brightness setting
- Ⓑ Low charge warning, 3 flashes
- Ⓒ Remaining burn time approx. 3 minutes
- Ⓓ Low discharge protection warning with continuous flashing
- Ⓔ Lamp shuts down in discharge protection mode
- Ⓕ Lamp may be turned back on to 25% brightness setting
- Ⓖ Continuous flashing
- Ⓗ Lamp shuts down
- Ⓘ Emergency mode signalled with 6 flashes
- Ⓝ Remaining burn time approx. 1 minute

REFERENCE CYCLE

To ensure the highest possible accuracy of the electronics and the best information in the display for future dives, the lamp should undergo a reference cycle. (We recommend that this is carried out every 6-12 months).

Procedure:

Regardless of the state of charge, the cells must be charged using an approved charger until the charge switches off automatically.

Make sure the lamp is equipped with the standard 50W halogen bulb or the LED module.

Within 20 hours of completing the charge, fully immerse the closed lamp in a bucket or basin filled with cold water and turn the lamp on to the maximum 125% power setting until the lamp switches off automatically (usually after approx. 60 minutes). Do not press any buttons before the lamp automatically switches off. After the lamp has switched off automatically, the electronics will be recalibrated and the display will show the remaining burn time and cell capacity with the greatest possible accuracy.

EXPERT SETTINGS OF THE ELECTRONICS

(advanced programming for technically interested users)

PROGRAMME MODE

To operate the lamp, individual preferences can be selected in different programmes. The programme set appears in the top right hand corner of the display when both switches are pressed simultaneously. (A,B,C, or T). If both switches (+/-) remain pressed, after 15 seconds the programme will change approx. every 3 seconds to the next programme, (A,B,C,T,A,B,C,T,...). Releasing the switches will store the last displayed programme in the power pack. After replacing a power pack, the stored programme will be activated.

Program A: Lamp only ON/OFF
(simplest operation)

Program B: Lamp dimmer in 5 stages of 25% from 25% to 125%
(comfort operation mode – default setting for standard use)

Program C: Lamp dimmer infinitely variable in 5% steps from 25% to 125%
(individual operation mode for advanced users)

Program T: Lamp is only ON as long as the switches are pressed
(Morse operation mode for professional use)

DESCRIPTION OF THE SWITCH UNIT**Program A:**

By pressing the plus (+) switch, the lamp is turned on to 125% power. The minus (-) switch turns the lamp off.

Program B /Standard :

Each time the + switch is pressed for approx. ½ second, the lamp power will increase 25%. The – switch operates in the same way to reduce the power 25%. When the lamp has reached the max. or minimum power setting and the switch is pressed again, the lamp will blink once to show that the end of the scale has been reached. If the + switch is pressed for approx. 1 second, the lamp is turned on to its max. (125%) power setting. The – switch pressed for approx. 1 second will turn the lamp off.

Program C:

If the + switch is pressed continuously, the lamp will increase the power (in 5% steps) until the maximum power is reached (125%) when the lamp will blink once. Pressing the – switch continuously will reduce the power in 5% steps to the minimum power setting of 25% when the lamp will blink once.

If the – switch is pressed for only approx. ½ second, the lamp will turn off.

Pressing the + switch for only approx. ½ second will turn the lamp on to its last power setting.

Program T:

In programme T, the lamp stays on as long as the + switch is pressed for sending Morse signals. The power is 125%.

EXPERT INTERROGATION OF THE DATA MEMORY
(advanced data recall for technically interested users)

DATA STORAGE

The micro processor in the electronics and the controller in the cell pack match each other and allow multiple data to be collated and stored. Some of the data can be recalled and viewed in LCD Display using the operating buttons.

To enter the data mode, press the – button for approx. 15 seconds. „000000“ will appear in the LCD display. With the – button still pressed in, pressing the + button will scroll through the data menu numbers 1 through to 17. The menu number appears in the top left corner of the LCD display while the data appears in the LCD display.

Menü	Data Display	1.line	2.line	
1	digit serial number	1 xx	xxx	Num
2	Date of manufacture	2	MM.J	
3	Software version of the switch unit in the hand grip	3 H	xx.x	Num
4	Software version of the cell pack	4 A	xx.x	Num
5	Actual temperature	5	xx	°C
6	Max. Temperature value	6	xx	°C
7	No of charge cycles (min. +1%)	7	xxx	Num
8	No of full charges above 90%	8	xxx	Num
9	No of discharges to continuous blinking (0%)	9	xxx	Num
10	No of discharges up to shut down	10	xxx	Num
11	No of reactivations after shut down	11	xxx	Num
12	Total duration of use	12	xxx	Std
13	Maximum charging current	13	x.x	A
The following data is updated every 24 hours				
14	Storage with less than 40% capacity	14	xxx	%
15	Storage with 40-70% capacity	15	xxx	%
16	Storage with more than 70% capacity	16	xxx	%
17	Days of storage since the last use	17	xxx	Num
18	Charge status after the last use	18	xxx	%

EXTENSION OF THE WARRANTY

The current EEC regulations call for a 6 Month warranty of rechargeable cells. If the cells in your lamp are handled with care the average life expectancy is 4 - 6 years or 300 – 500 charge/discharge cycles. Incorrect handling of the cells will shorten this life expectancy drastically. The data stored in the electronics serves as a reference and can be analysed in the interest of the consumer to extend the warranty. Should the power pack fail within 2 years after purchase, and the data in the memory shows correct handling of the cells, a warranty repair or a fair offer will be made.

AFTER EACH USE

Warning!



After the dive is completed, examine the lamp for signs of flooding or water ingress as soon as possible. To carry out this check, hold the lamp upside down with the glass plate pointing down and look at the glass plate from the side for any signs of moisture/water ingress.

After each use, the lamp should be thoroughly rinsed in clean, fresh water. During this rinsing, operate the switches.

When the lamp is operating, the temperature in the housing will increase and a slight overpressure will form inside the housing. If the housing is opened immediately after use, this slight overpressure will cause excessive friction on the threads of the covers and/or the O-ring seals, the cover will be difficult to open. For this reason we recommend that the lamp is left unopened (unless flooding has occurred) for several minutes after it is switched off.

TRANSPORT

TRANSPORT LOCK



After use, the transport lock must be initiated to prevent inadvertent operation of the lamp.

To move the transport lock into the lock position, push it up towards "lock". Make sure the lock clicks into the locked position. Check the operating buttons to make sure they cannot be operated, if necessary repeat the locking procedure. To operate the lamp, push the slide towards the „unlock“ position.

Warning !



If the lamp is to be transported or stored without direct supervision, the halogen bulb must be removed from the socket and stowed (see page 10). This is a precaution in case a defective electronic module turns the lamp on. This heat generated by the halogen bulb may cause damage to items adjacent to the lamp/glass/bulb.

STORAGE

For extended periods of storage, the cell pack should be removed, the halogen lamp removed from the socket and stowed and the housing should be closed. Place the cell pack on a suitable surface (non sensitive) and store in a dry environment between 10° - 20°C (50 – 68°F). Under no circumstances should the lamp be subjected to temperatures above 45°C (110°F). If a cell pack is continuously stored at full charge and increased temperatures, the cell pack will suffer from an irreversible reduction of capacity of more than 10% per year.

If the cell pack is to be stored for an extended period of time, the cell pack should be stored at a low temperature with a capacity of 50-60%. (see special charging functions on page 21). The irreversible loss of capacity due to natural loss of capacity over time can be reduced to as little as 3% with good care and attention. The lithium manganese cells are subject to a very small natural discharge (depending on the ambient temperature this is approx. 4-8% per month, and the electronic in the lamp that monitor the conditions result in approx. 3% discharge per month).

If the cell pack is stored for extended periods of time, it should be recharged every 4-6 months to approx. 50-60% capacity.

A completely discharged cell pack is protected by the electronic monitoring that prevents further charging. In this case, return the cell pack to the manufacturer for evaluation.



CHARGING

GENERAL INFORMATION CONCERNING CHARGING RE-CHARGEABLE CELLS

The **lithium manganese re-chargeable cells** used in this lamp have been declared as gas and acid/alkali sealed. For this reason the electrolyte in the cells cannot escape and the cells can be charged regardless of their environment. This positive feature has been stated by the cell manufacturer but an exception to this cannot be ruled out.

Re-chargeable cells can, if defective, produce an internal pressure in the cell during charging/discharging (use) that may cause the over pressure device integrated in the cell to open. This in turn will allow electrolyte to escape from the cell. Electrolyte is an aggressive alkali and also conducts electrical current, this will destroy the cell over time. The resulting electrolysis will create an over-pressure inside the housing of the lamp.

For this reason, rechargeable cells should not be charged within a closed underwater housing on repeated occasions.

MEMORY-EFFECT

The so-called memory effect will occur when re-chargeable cells are regularly charged in a partly discharged state (for example this occurs when a wireless telephone is placed in the charging station every evening). The popular rule of thumb to only charge re-chargeable cells when they are completely discharged is applicable to NC (nickel cadmium) or NMH (nickel metal hydride) cells. This rule does not apply to underwater lamps with high discharge currents, in this case, the regular full discharge has a negative effect on the cells. The lithium manganese cells used in this lamp do not have a memory effect.

Warning !



Regularly discharging a multi cell power pack may damage the voltage features of individual cells within the cell pack, thus causing an unbalance within the cell pack that in turn may cause the weakest (and therefore the most susceptible) cell to fail prematurely. The more often the cell pack is discharged to the point where the discharge protection cuts in, the greater the chance that an individual cell will fail within the cell pack.

PREPARATION FOR CHARGING



For the charging procedure you will need a clean, dry working area with a mains socket nearby. Charge the cells in an environment which is as dry and clean as possible, with a resistant work surface. (Sealed cells can also leak under poor conditions). The ambient temperature should not exceed 40°C (104°F).

Note that a defective electronic module may cause the lamp to turn on during charging. Damage to adjacent material caused by the resulting heat generated by the halogen bulb must be avoided. For this reason we recommend that the halogen bulb is removed during charging.

There are two methods for charging the lamp.

I. INTERNAL CHARGING CONNECTION

The charging connection is located on the cell pack, the cell pack must be removed for charging.

Open the rear cover on the lamp housing and remove the power pack (see page 8).

The charging connections are marked with + (red/right contact) and – (blue/left contact).

Warning !



Check the condition of the charging sockets and cell pack regularly and examine for signs of corrosion, oxidation or leakage. Examine the sleeves surrounding the cells for signs of bubbling or traces of a white, floury residue between the cells in the cell pack. In any of the above conditions are found, do not charge the cell pack ! Return the lamp to the manufacturer for evaluation, pack the cell pack and the housing separately.

Warning !



The temperature of the individual cells should also be checked regularly by feeling the temperature during charging. If one or more cells is hot to touch then this may indicate a defective cell or cell pack. Do not use this cell pack, return it to the manufacturer for evaluation or replace the cell pack with a new one.

II. EXTERNAL CHARGING CONNECTION

The charging connection is on the outside of the housing, the cell pack remains in the lamp housing during charging.

This method of charging is advantageous when the ambient conditions are unsuitable for opening the housing, the cell pack is charged via the external connections located on the rear of the housing.

The charging connections are marked with + (red/right contact) and – (blue/left contact).

Warning !



Because the cell pack cannot be examined whilst using this method of charging, we recommend that it should only be carried out in exceptional circumstances. After the lamp has been charged repeatedly using the external charging connections, the cell pack must be examined for signs of damage/deterioration !

Before the plugs are plugged into the charging connections, the sockets must be thoroughly cleaned and dried (e.g. with an air blast or with a Q Tip). Moisture can lead to oxidation and/or charring of the connections during charging.

CHARGE MONITORING

If the LCD display blinks quickly on all elements in the display, there is either no cell pack connected to the electronics or the cell pack full discharge protection is activated.

Remove the charging plug and either fit a cell pack correctly into the lamp, or remove the fully discharged cell pack and return to the manufacturer for evaluation and replace the defective cell pack with a suitable cell pack.

The electronics also monitor the temperature of the cells during the charge process and stop the charging or prevent it from starting if the cell temperature exceeds 40°C (104°F)



Despite the redundancy of the controlling electronics, the temperature of the individual cells should also be controlled manually.

It is recommended that the cells are touched by hand with caution as defective cells that overheat can cause injury through burns!

Warning!



If the temperature difference between the individual cells is unequal or one or more cells are overheating during the charging process, stop the charging process immediately and return the cell pack to the manufacturer for evaluation. Replace the cell pack with a serviceable cell pack.

LCD DISPLAY DURING CHARGING

During the charging process, the charge status is shown as a percentage (%) in the bottom line of the LCD display. To show that the cell pack is actually being charged, an animation of a line will appear in the top of the LCD display. The LCD background light will be activated during the charging process.

When the charging process is completed, the electronic will cut off the charge current and the LCD display will show 100% capacity. The animation in the top of the display will disappear and the background lighting will switch off.

To ensure a complete full charge, the charge will automatically turn back on 2 or 3 times within an hour (approx. 2% "top-up charge").

SPECIAL FUNCTION FOR THE OPTIMUM STORAGE OF CELL PACKS

When the charger is connected via the charging socket to the cell pack and the – button is pressed for approx. 15 seconds, the charge will only charge the cells up to 60% capacity in preparation for extended periods of storage. This procedure is confirmed by a blinking 60 in the LCD display and an animation in the upper part of the LCD display.

This process can be stopped by pressing the + button.

NON-ORIGINAL CHARGERS

Warning !



Only chargers that have been approved by the manufacturer in advance of use may be used for charging the lamp. Using non-approved chargers, voids the manufacturer's warranty.

Use of non-original chargers may damage the electronic module that monitors the cell pack condition. The cells can overheat and/or be damaged. (Risk of explosion !).

Use of chargers that are not previously approved by the manufacturer is an alteration to the original design.

This voids the warranty and any releases the manufacturer of any responsibility and liability for subsequent damage and/or injury.

**CHARGER OFF-SHORE 1/12**

Use only manufacturer approved cells, do not connect any non-approved cells.

The charger off-shore 1/12 is suitable for charging the **maxi compact LCD**.

The max. charging current is approx. 1.0 Amps.

The charging time for the **maxi compact LCD** is approx. 4.5 hours.

The charger uses the latest technology with a wide range input voltage rating and accepts any voltage between 100 and 250V and frequencies between 45 and 65 Hz. It is not necessary to mechanically pre-select the local voltage.

All **Hartenberger** cell packs with 10-12 cells (12 – 14.4V) are identified by the charger when connected and will have an optimal; efficient charge.

Firstly, plug the charging plugs into the back of the lamp or the cell pack. Be careful not to use undue force when plugging the plugs in and ensure the plugs are inserted straight to avoid damage. Make sure the markings and colour coding match.

+ /red right socket for the red plug,

- /blue left socket for the blue plug.

Connect the charger adapter cable with the charger .

Take care to avoid short circuiting the contacts with metal or conductive objects. Ensure that the charger has suitable cooling to avoid over heating especially if it is operated in extreme conditions.

The charger is activated by plugging the charger into a standard mains socket that meets the voltage/hertz specifications on the charger. The charger is fitted with a standard „Euro“ plug adapter when delivered and a range of adapters for the common international mains sockets are also supplied. The correct adapter should be fitted onto the charger after removing the “Euro” plug adapter before attempting to plug the charger into a non “Euro” mains socket.

All the functions of the charger are shown via the LED on the charger.

Functions shown via the LED when charging NC or NMH cells:

LED on	Mains power is connected, the cells are being charged.
LED off	Mains power is not connected and/or cells are not being charged.
LED flashes slowly	Trickle charge, cells are 100% charged.
LED flashes quickly	Cells are discharged completely.

Functions shown via the LED when charging Lithium Manganese cells:

LED on	Mains power is connected, the cells are being charged.
LED off	Mains power is not connected. Cells are not connected. Cells are charged Cells are discharged completely.

The charging process of the *maxi compact LCD* with standard lithium manganese cells is monitored by the electronics in the lamp/cell pack. These electronics cut off the charging current when the cells are fully charged. The LCD display shows the 100% (or 60% in the case of a limited charge before storage, see page 21), the animation ceases to flash and the background lighting is switched off.



CHARGER OFF-SHORE II

Use only manufacturer approved cells, do not connect any non-approved cells.

The charger off-shore II is suitable for charging the High-Tech-Lamp **maxi compact LCD**.

The max. charging current is approx. 1.8 Amps.

The charging time for the **maxi compact LCD** is approx. 2.5 hours.

The charger uses the latest technology with a wide range input voltage rating and accepts any voltage between 100 and 250V and frequencies between 45 and 65 Hz. It is not necessary to mechanically pre-select the local voltage.

All **Hartenberger** cell packs with 5-12 cells (6 – 14.4V) are identified by the charger when connected and will have an optimal efficient charge.

First connect the charger to the mains by plugging in the mains cable. All the functions of the charger are displayed via 2 LEDs.

LED 1 - Functional display

Green	Mains supply connected, charger is functioning correctly.
Red	Mains supply connected, charger is overloaded or defective.
Off	No mains supply connected.

Firstly, plug the charging plugs into the back of the lamp or the cell pack. Be careful not to use undue force when plugging the plugs in and ensure the plugs are inserted straight to avoid damage. Make sure the markings and colour coding matches.

+ / red right socket for the red plug,

- / blue left socket for the blue plug.

Connect the charger adapter cable with the charger .

Take care to avoid short circuiting the contacts with metal or conductive objects. Ensure that the charger has suitable cooling to avoid over heating especially if it is operated in extreme conditions.

LED 2 functional display when charging NC or NMH cells:

Red	No cell pack connected (pause).
Green blinks	Fast charge to 100 % of the cell pack capacity.
Off	Trickle charge, cell pack is 100% charged.

LED 2 functional display when charging lithium manganese cells:

Red	No cell pack connected (pause).
	Cell pack is fully discharged
	Cell pack is 100% charged

Green blinks Fast charge until the cells reach 100% (or 60%).

The charging process of the *maxi compact LCD* with standard lithium manganese cells is monitored by the electronics in the lamp/cell pack. These electronics cut off the charging current when the cells are fully charged. The LCD display shows the 100% (or 60% in the case of a limited charge before storage, see page 21), the animation ceases to flash and the background lighting is switched off.

CARE AND MAINTENANCE

HOUSING

We recommend that from time to time the housing surface is impregnated with silicone. The chance of calcium depositing on the surface of the lamp is reduced and the scratch resistance properties of the housing surface are also improved. (Action to be taken Interval By Owner)

Action to be taken	Interval	By Owner	Workshop
Examine wrist strap / hand line for integrity/damage	Before each use	X	
Examine the O rings and sealing surface of the end covers for damage, contamination and/or deterioration, clean and lubricate as necessary	Every time the lamp housing is opened latest after 6 months or 50 times use	X	
Replace the O rings in the covers	Every 12 months or earlier if damaged	X	
Clean and dry external charging connections	Before each external charge	X	
Rinse under and around the switch with fresh water while moving the switch	After each dive	X	
Impregnate the housing with silicone grease	After several uses as necessary	X	
Replace the O rings under the rear cover (charging connections, display)	Every 500 dives or every 5 years at the latest		X
Replace the O ring in the front cover (glasses)	If damaged / deteriorated or every 5 years at the latest		X
Replace the halogen bulb	Life expectancy approx 100 hours	X	
Replace cell pack	Life expectancy up to 500 operating hours	X	

SERVICE LOG O RING / HALAOGEN BULB REPLACEMENT

O-Ring 58x3,0 Glass plate	O-Ring 48x3/48x1,6 front cover	O-Ring 48x3/48x1,6 rear cover	Halogen bulb
Notes:			

CLEANING THE SWITCH MECHANISM

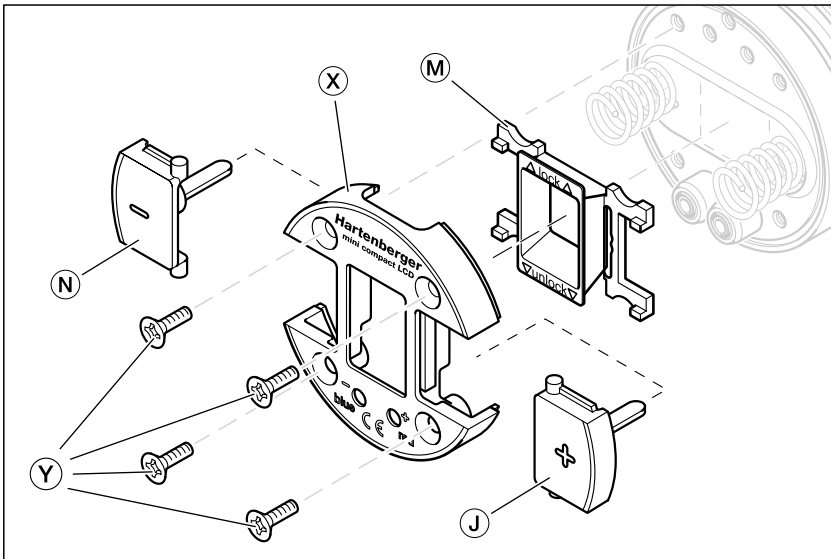

Fig. 7: switch mechanism

STRIPPING DOWN/REASSEMBLING THE SWITCH MECHANISM

If the switches start to stick, they must be cleaned by rinsing the lamp under fresh clean water for an extended period. Operate the switches under water to restore the correct function. If this is not successful, the switches must be removed by removing the entire rear cover. This work can be carried out by a lay person with technical skills and the appropriate tools.

To prevent the lamp from inadvertently switching on during the cleaning procedure, the cell pack should be removed from the lamp before the cleaning procedure starts (see page 11).

Remove the four cross head screws (Y), the switch cover (X) with the two buttons (N O) and slide the transport lock slide (M) carefully off. Pull off the two springs from the display screen. The optical display screen can now be rinsed to remove any salt/sand/foreign debris that has become deposited over time. A thin cotton bud tip can be used to carefully clean the area exposed.

Assemble the switch and transport lock components in the reverse order, make sure the threads of the 4 cross heads screws are lightly coated with silicone grease and screwed down hand tight.



FAULT DIAGNOSIS

Problem	Cause	Action to be taken
Water enters the housing: 1. A few drops are present. 2. Housing is flooded with fresh water. 3. Housing is flooded with Saltwater.	Defective or contaminated O-Ring.	* Abort the dive as soon as is safely possible. Open the lamp. 1. Dry the lamp and power pack with a clean cloth. 2. Dry the power pack and return it to the manufacturer 3. Rinse the lamp and power pack with ample fresh water and return the lamp to the manufacturer.
Switches sticking	Sand or salt residue in the mechanism	Clean the switches (see below)
Lamp does not illuminate.	1. Cells are discharged 2. Bulb is defective	1. Charge cells 2. Replace halogen bulb
Housing screw covers are hard to unscrew	1. Housing cover threads/O-rings are contaminated 2. Threads damaged	1. Clean and lubricate housing covers and/or O-rings 2. Return lamp to manufacturer
LED does not illuminate.	1. No Mains. 2. Charging cable not plugged in. 3. Bad contact on charging plug.	1. Check mains supply 2. Plug in charging cable. 3. Check charging plug security

*** Warning !**



Danger of explosion if flooding occurs !

If water ingresses into the housing, oxidation will occur and the resulting gas/pressure build up may cause an explosion.

Never look directly towards the lamp glass plate. In the event of rapid pressure build up inside the housing, the glass may explode out of it's fitting.

If the housing cover cannot be opened, the rear cover of the +/- buttons must be unscrewed and removed.

To release the pressure built up in the housing, carefully pull off the plastic liners from around the charging sockets using suitable pliers/grips.

Warning !



There is a possibility that the flooding may also create an aggressive chemical solution that may cause injury such as burns if it comes into contact with the skin, eyes, etc. or if it is ingested. Inhalation of the gases should also be avoided.

SPARE PARTS

Bulb	Power Output	Socket	Lifetime (hours)
Halogen Bulb HLX	30W	G 6,35	ca. 100
Halogen Bulb HLX	50W	G 6,35	ca. 100
Halogen Bulb HLX	100W	G 6,35	ca. 100

O-Ring	Dimensions	Elasticity	Material
Glass	58 x 3,0	50° shore Härte	Viton blue
Window LCD	56 x 3,0	50° shore Härte	Viton blue
Screw Fitting	48 x 3,0	50° shore Härte	Viton blue
Screw Fitting	48 x 1,6	50° shore Härte	Viton blue

ACCESSORIES**NEOPRENE SLEEVES**

Neoprene sleeves for the housing offer protection and a reduction in weight in the water and are available in the colours yellow and black.

CARRYING BAG MAXI COMPACT LCD

Nylon bag for transporting the lamp and offering some protection in a dive bag.

CARRYING BAG CHARGER OFF-SHORE 1/12

Nylon bag for transporting the charger and offering some protection in a dive bag.

CARABINER CLIPS

For securing the lamp to a suitable point on the diving equipment.

CARABINER CLIPS WITH SPIRAL CABLE

For securing the lamp to a suitable point on the diving equipment with a spiral cable for additional security

SPOT REFLECTOR MODULE (STANDARD)

Reflector unit with a narrow beam for penetrating illumination

FLOOD REFLECTOR MODULE

For film or video use for an even illumination over the entire beam.

LED-MODULE (OPTIONAL)

LED-Module (7 x 3,5 Watt, spot), recommended for diving in fresh water.

SPARE CELL PACK

Cell pack for the maxi compact LCD 14,4V/5,4Ah lithium Manganese cell pack for quick replacement of a discharged/defective cell pack.

Unserviceable cells/cell packs should not be thrown in the normal rubbish. These cells should be disposed of through the correct channels to prevent danger to the environment and/or injury. Do not throw the cells into a fire, there is a danger of explosion and/or injury.

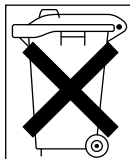

Hartenberger

*Unterwassertechnische Geräte GmbH
Rennebergstr. 19 D - 50939 Köln*

Tel.: +49 221-415000

Fax.: +49 221-415050

info@hartenberger.de

www.hartenberger.de